

Die vierfache Vermittlung der Zeichenrelation durch den Objektbezug

1. In Toth (2019) hatten wir folgende Symbole für die drei von Bense im Rahmen seiner Raumsemiotik (vgl. Bense/Walther 1973, S. 80) unterschiedenen ontischen Objektarten eingeführt

Sys := □

Abb := ⊐

Rep = —

Genau so, wie also die „generativen“ Relationen in den Trichotomien der drei Triaden des Zeichens von maximaler Konkretion zu maximaler Abstraktion verlaufen, d.h. vom Quali- über das Sin- zum Legizeichen, vom Icon über den Index zum Symbol und vom Rhema über das Dicent zum Argument, so wird die „ontische Trichotomie“ durch zunehmende topologische Öffnung der Symbole angedeutet. Wir erhalten damit die vollständige Isomorphie von Zahl, Zeichen und Objekt, die wir in dem folgenden Schema darstellen

Zahl	≅	Zeichen	≅	Objekt
1	≅	1.	≅	□
2	≅	2.	≅	⊐
3	≅	3.	≅	— .

Entsprechend dem von Bense (1975, S. 37) benutzten Verfahren, Matrizen durch kartesische Produkte zu konstruieren, können wir damit drei zueinander paarweise isomorphe Matrizen, eine Zahlenmatrix, eine Zeichenmatrix und eine Objektmatrix, konstruieren.

	1	2	3	≅		.1	.2	.3	≅		□	⊐	—
1	11	12	13		1.	1.1	1.2	1.3		□	□□	□⊐	□—
2	21	22	23		2.	2.1	2.2	2.3		⊐	⊐□	⊐⊐	⊐—
3	31	32	33		3.	3.1	3.2	3.3		—	—□	—⊐	—

2. Im Gegensatz zur Isomorphie

$1 \cong 1. \cong \square$

und zur Isomorphie

$3 \cong 3. \cong \text{—}$

stellt sich jedoch die Isomorphie

$2 \cong 2. \cong \sqsubset$

als nicht-eindeutig heraus, denn \sqsubset ist nur eine von vier möglichen Öffnungsgraden semiotisch zweitheitlich fungierender ontischer Objekte

$\sqsubset, \sqcup, \sqsupset, \sqcap$,

d.h. wir haben eine rechtsmehrdeutige Abbildung der Form

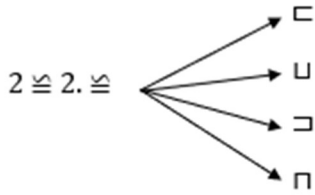

Wegen der ontisch-semiotischen Isomorphie folgt daraus für die bensesche Zeichenzahlenrelation (vgl. Bense 1981, S. 17 ff.)

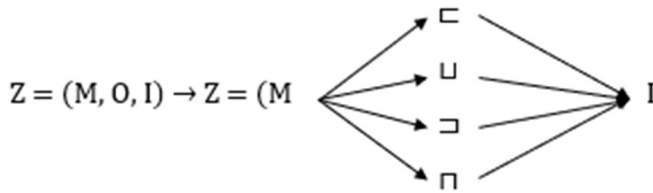

Wenn wir also die offenen Seiten mit r, o, l, u indizieren, können wir den vierfachen Objektbezug in der Zeichenrelation durch

$Z = (M, (O_r, O_o, O_l, O_u), I)$

ausdrücken, d.h.

Z ist keine triadische Relation der Form Z^3 mehr, sondern eine der Form $Z^{1,4,1} = (M^1, O^4, I^1)$, wobei natürlich die kategoriethoretische Ordnung

$Z = (M \rightarrow ((M \rightarrow O) \rightarrow (M \rightarrow O \rightarrow I)))$

in der neuen Form

$$Z = (M^1 \rightarrow ((M^1 \rightarrow O^4) \rightarrow (M^1 \rightarrow O^4 \rightarrow I^1)))$$

bestehen bleibt.

Literatur

Bense, Max, Semiotische Prozesse und Systeme. Baden-Baden 1975

Bense, Max, Axiomatik und Semiotik. Baden-Baden 1979

Bense, Max/Walther, Elisabeth, Wörterbuch der Semiotik. Köln 1973

Toth, Alfred, Eine ontische Objektmatrix. In: Electronic Journal for Mathematical Semiotics, 2019

Präambel zur Theorie der Vermittlung topologischer semiotischer Relationen

1. In Toth (2019a) hatten wir argumentiert, daß die Definition der drittheitlichen Trichotomie überflüssig und zudem inkonsistent ist, weil sie erstens die logische Subjektposition repräsentiert, aber von Peirce, Bense und Walther (1979) topologisch und logisch definiert wird. Zweitens weil der Zusammenhang von Zeichen ein Problem einer Zeichensyntax ist, aber keine Eigenschaft des Zeichens selbst (vgl. Klaus 1962). Bense selbst hatte das Zeichen wiederholt rein mathematisch definiert, so etwa kategorietheoretisch in (1979, S. 53 u. 67) oder zahlentheoretisch in (1981, S. 17 ff.). Drittens lassen sich die ersten zwei Trichotomien durch

$$(x.1): \quad Z = f(\Omega)$$

$$(x.2): \quad Z = f(\omega, t)$$

$$(x.3): \quad Z \neq f(\Omega)$$

mit $x \in (1, 2)$ definieren, was jedoch für die dritte Trichotomie nicht möglich ist, da der Zusammenhang von Zeichen keine Funktion des Objektes, sondern eine solche einer Menge von Zeichen ist

$$Z = f(Z).$$

Für den Trivialfall, daß die Menge aus dem Zeichen selbst besteht, gilt dann natürlich

$$Z = f(Z).$$

Es genügt also völlig, von der semiotischen 2×3 -Teilmatrix

	.1	.2	.3
1.	1.1	1.2	1.3
2.	2.1	2.2	2.3

auszugehen und jedes Subzeichen der Form

$$S = (x.y)$$

mit $x \in (1, 2)$ und $y \in (1, 2, 3)$

durch

$$(x.1) = f(\Omega)$$

$$(x.2) = \underline{f}(\omega, t)$$

$$(x.3) \neq f(\Omega)$$

zu definieren. Ein offener Konnex kann dann definiert werden durch

$$(x.y),$$

ein abgeschlossener Konnex durch

$$(x.y] \text{ oder } [x.y)$$

und ein vollständiger Konnex durch

$$[x.y].$$

Bei den dicentischen Konnexen ergibt sich also eine systematische Doppeldeutigkeit. Da ferner der Interpretantenbezug in den semiotischen Relationen syntaktisch und nicht mehr kategorial angegeben wird, fällt auch die ad hoc-Bestimmung, daß ein Zeichen zwar durch $P = (1, 2, 3)$, eine Zeichenklasse aber in der konversen Ordnung $ZKI = (3, 2, 1)$ als Folge der „pragmatischen“ Maxime von Peirce definiert wird, weg. Wir müssen also die $27 + 9 = 36$ semiotischen Relationen, die über einer 2×3 -Matrix generierbar sind, in den folgenden Normalformen angeben (vgl. Toth 2019b-d). Dadurch erhält man somit eine vollständige syntaktische Semiotik, d.h. eine dyadisch-trichotomische Semiotik, deren Interpretantenkonnexe auf syntaktischem Wege ausgedrückt werden.

(1.1, 2.1)	(1.1, 2.1]	[1.1, 2.1)	[2.1, 1.1]
(1.1, 2.2)	(1.1, 2.2]	[1.1, 2.2)	[2.1, 1.2]
(1.1, 2.3)	(1.1, 2.3]	[1.1, 2.3)	[2.1, 1.3]
(1.2, 2.1)	(1.2, 2.1]	[1.2, 2.1)	[2.2, 1.1]
(1.2, 2.2)	(1.2, 2.2]	[1.2, 2.2)	[2.2, 1.2]
(1.2, 2.3)	(1.2, 2.3]	[1.2, 2.3)	[2.2, 1.3]
(1.3, 2.1)	(1.3, 2.1]	[1.3, 2.1)	[2.3, 1.1]
(1.3, 2.2)	(1.3, 2.2]	[1.3, 2.2)	[2.3, 1.2]

(1.3, 2.3) (1.3, 2.3] [1.3, 2.3) [2.3, 1.3]

2. Insgesamt gibt es also $36 \text{ mal } 36 = 1296$ paarweise Kombinationen von Paaren von Subzeichenzahlen, die wir in Toth (2019f) hinsichtlich der in der semiotischen Kommunikationstheorie sowie in der semiotischen Kreationstheorie benutzten Tripel als die bisher wohl umfangreichste Datenbasis für topologische qualitative (semiotische) triadische Relationen dargestellt haben. Diese Datenbasis, die in 10 mal 65 Kapiteln mit je zwischen ca. 1000 und über 2000 Seiten somit hochgerechnet rund eine Million Druckseiten umfaßt, kann als Implementationsbasis etwa für zelluläre semiotische Automaten (vgl. z.B. Toth 2019 g, h) verwendet werden. Vergleichbar damit sind lediglich die auch als "claviatures" bekannten morphischen CA-Patterns von Rudolf Kaehr (vgl. Kaehr 2015), bei denen polykontexturale zelluläre Automaten auf der Basis der drei von Günther (1976-80) unterschiedenen drei Typen von morphogrammatischen Sterlingzahlen 2. Art, also Proto-, Deutero- und Tritozahlen, die Implementationsbasis bilden. Damit ist also ein weiteres Kapitel in der erst durch das Eindringen der Computerwissenschaft in die Mathematik ermöglichten dritten mathematischen Disziplin, der experimentellen (neben der theoretischen und der angewandten) Mathematik, geschrieben: der Visualisierung qualitativer Zahlen und ihrer dynamischen Veränderungen nicht nur in toten, sondern auch in lebenden Systemen. Die visuelle Darstellung der in Toth (2019f) dargestellten vollständigen Theorie der Vermittlung topologischer semiotischer Relationen bleibt vorderhand ein Projekt experimenteller mathematischer Semiotik von gigantischem Ausmaß.

Im Gegensatz zu den polykontexturalen Zahlen (vgl. dazu eingehend Kronthaler 1986), welche den logischen Identitätssatz und damit die ganze Basis der 2-wertigen aristotelischen Logik außer Kraft setzen, sind allerdings die von uns verwandten 10 qualitativen Zahlen alle im Rahmen der Gültigkeit der aristotelischen Logik angesiedelt (vgl. dazu Toth 2018a, b). Es handelt sich um folgende aristotelische qualitative Zahlen.

1. Peanozahlen

$P = (1, 2, 3)$

2. Surreale Zahlen (Conway-Zahlen)

$C = ((x.\{0 | \}), (x.\{0, \{0 | \} | \}), (x.\{0, \{0 | \} | \} | \}))$

3. Eisenstein-Zahlen

$$E = ((1+\omega), (2+\omega), (3+\omega))$$

4. Quadrarektische Zahlen (Kaehr-Zahlen)

$$K = (\lrcorner, \llcorner, \lrcorner)$$

5. Systemische Zahlen

$$S = (A(I), I(A), I(I))$$

6. Regionale Zahlen

$$L = ((-a.b), (a.-b), (a.b))$$

7. Relationale Zahlen

$$R = ((0, (1)), ((1), 0), (1, (0)))$$

8. Qualitative Zahlen

$$Q = (\mathbf{1}, \mathbf{2}, \mathbf{3})$$

9. Raumsemiotische Zahlen (Bense-Zahlen)

$$B = (\square, \rightarrow, -)$$

10. Abbildungszahlen

$$A = ((1\rightarrow 2), (2\rightarrow 3), (1\rightarrow 3))$$

Literatur

Bense, Max, Die Unwahrscheinlichkeit des Ästhetischen. Baden-Baden 1979

Bense, Max, Axiomatik und Semiotik. Baden-Baden 1981

Günther, Gotthard, Beiträge zur Grundlegung einer operationsfähigen Dialektik. Bd. 1. Hamburg 1976

Kaeher, Rudolf, Kähr's Catalog of morphic CA-Patterns. 5 Bde. Glasgow 2015

Klaus, Georg, Semiotik. Berlin (DDR) 1962, 4. Aufl. München 1973

Kronthaler, Engelbert, Grundlegung einer Mathematik der Qualitäten. Frankfurt am Main 1986

- Toth, Alfred, Entwurf einer semiotisch-relationalen Grammatik. Tübingen 1997
- Toth, Alfred, Kontexturierung der qualitativen Zeichenzahlen. In: Electronic Journal for Mathematical Semiotics, 2018a
- Toth, Alfred, Ortsfunktionalisierung der polykontexturalen Zahlen. In: Electronic Journal for Mathematical Semiotics, 2018b
- Toth, Alfred, Was und wie repräsentieren semiotische Trichotomien? In: Electronic Journal for Mathematical Semiotics, 2019a
- Toth, Alfred, Die Definition der triadisch-trichotomischen Zeichenrelationen mit Hilfe der 2×3 -Teilmatrix. In: Electronic Journal for Mathematical Semiotics, 2019b
- Toth, Alfred, Syntaktische Semiotik. In: Electronic Journal for Mathematical Semiotics, 2019c
- Toth, Alfred, Topologische semiotische Kategorien. In: Electronic Journal for Mathematical Semiotics, 2019d
- Toth, Alfred, Paarweise Kombinationen von Paaren von Subzeichenzahlen. In: Electronic Journal for Mathematical Semiotics, 2019e
- Toth, Alfred, Theorie der Vermittlung topologischer semiotischer Relationen. 10 Bde. zu je 65 Kapiteln. In: Electronic Journal for Mathematical Semiotics, 2019f
- Toth, Alfred, Theorie zellulärer semiotischer Automaten zur Grundlegung einer ontischen Nacht. In: Electronic Journal for Mathematical Semiotics, 2019g
- Toth, Alfred, Skizze einer semiotischen zellulären Automatentheorie. In: Electronic Journal for Mathematical Semiotics, 2019h
- Walther, Elisabeth, Allgemeine Zeichenlehre. 2. Aufl. Stuttgart 1979

Die ontischen Relationen als polykontexturale Vermittlungsrelationen

1. Die von Bense (1975, S. 35 ff.) eingeführte 3×3 -Matrix enthält bekanntlich in den Zeilen die Triaden und in den Spalten die Trichotomien

	.1	.2	.3
1.	1.1	1.2	1.3
2.	2.1	2.2	2.3
3.	3.1	3.2	3.3.

Da es sich hier um eine quadratische Matrix handelt, ist natürlich $n = m$.

Dagegen ist die in Toth (2019a) eingeführte dyadisch-trichotomische Matrix eine 2×3 -Matrix, bei der also $n \neq m$ gilt

	.1	.2	.3
1.	1.1	1.2	1.3
2.	2.1	2.2	2.3.

Während also die bensesche Zeichenrelation durch

$$Z^{2,3} = (3.x, 2.y, 1.z)$$

mit $x, y, z \in (1, 2, 3)$ definiert ist, ist unsere Zeichenrelation durch

$$Z^{2,3} = ((w.x), (y.z))$$

mit $w \dots z \in (1, 2, 3)$ definiert.

Wie in Toth (2019b) gezeigt wurde, kann man die Subzeichen der 2×3 -Matrix in einer Pseudo-Proto-Darstellung wie folgt anordnen

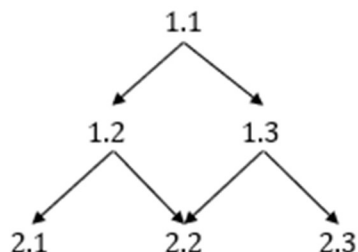

Dagegen ist die echte Proto- und die ihr gleiche Deutero-Darstellung für die Kontexturen $K = 1$ bis $K = 3$

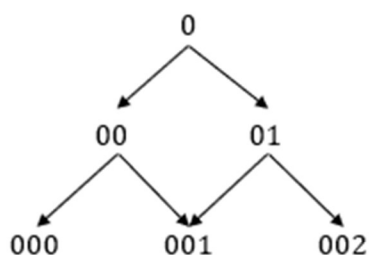

Dadurch sind wir erstmals in der Geschichte der polykontexturalen Semiotik, die mit Kronthaler (1992) und Toth (2003) begonnen hatte, imstande, die 6 Subzeichen von $Z^{2,3}$ einer (bijektiven) Kenose zu unterziehen, denn aus der Äquivalenz der Pseudo-Proto-Deutero-Struktur von $Z^{2,3}$ und der Proto-Deutero-Struktur von $K = 1$ bis $K = 3$ folgt

$$(1.1) \leftrightarrow 0$$

$$(1.2) \leftrightarrow 00$$

$$(1.3) \rightarrow 01$$

$$(2.1) \leftrightarrow 000$$

$$(2.2) \leftrightarrow 001$$

$$(2.3) \leftrightarrow 012.$$

2. Im folgenden betrachten wir die 10 invarianten ontischen Relationen (vgl. Toth 2016, 2017)

1. Arithmetische Relation

$$M = (\text{Mat}, \text{Str}, \text{Obj})$$

2. Algebraische Relation

$$O = (\text{Sys}, \text{Abb}, \text{Rep})$$

3. Topologische Relation

$$I = (\text{Off}, \text{Hal}, \text{Abg})$$

6. Zentralitätsrelation

$$C = (X_\lambda, Y_Z, Z_\rho)$$

7. Lagerrelation

$$L = (\text{Ex}, \text{Ad}, \text{In})$$

8. Ortsfunktionalitätsrelation

$$Q = (\text{Adj}, \text{Subj}, \text{Transi})$$

4. Systemrelation

$$S^* = (S, U, E)$$

5. Randrelation

$$R^* = (Ad, Adj, Ex)$$

9. Ordinationsrelation

$$O = (Sub, Koo, Sup)$$

10. Possessiv-copossessive Relationen

$$P = (PP, PC, CP, PP).$$

Da sie isomorph der triadischen semiotischen Relation sind, wie in zahlreichen Arbeiten aufgezeigt worden war, kann man sie als Vermittlungsrelationen dyadischer semiotischer Relationen einführen

$$Z^{3,3} = (3.x, 2.y, 1.z) = (V(2.y), (3.x, 1.z)),$$

durch Kenose

$$001 = V(000, 002)$$

und durch Semiose

$$(y.2) = V(x.1, z.3).$$

Durch Substitution erhält man also

$$Z^{2,3} = (w.x, y.z),$$

wobei in $Z^{2,3}$ die Vermittlung im Gegensatz zu $Z^{3,3}$ nicht kategorial, sondern durch die drei Formen von Abschlüssen mittels Klammerung bewerkstelligt wird.

Vermöge semiotisch-ontischer Isomorphie folgt also sofort

$$M = (Mat, Str, Obj) \rightarrow Str = V(Mat, Obj)$$

$$O = (Sys, Abb, Rep) \rightarrow Abb = \underline{V}(Sys, Rep)$$

$$I = (Off, Hal, Abg) \rightarrow Hal = \underline{V}(Off, Abg)$$

$$S^* = (S, U, E) \rightarrow U = \underline{V}(S, E)$$

$$R^* = (Ad, Adj, Ex) \rightarrow Adj = \underline{V}(Ad, Ex)$$

$$C = (X_\lambda, Y_z, Z_\rho) \rightarrow Y_z = V(X_\lambda, Z_\rho)$$

$$L = (Ex, Ad, In) \rightarrow Ad = (Ex, In)$$

$$Q = (Adj, Subj, Transi) \rightarrow \underline{Subi} = (\underline{Adi}, \underline{Transi})$$

$$O = (\text{Sub}, \text{Koo}, \text{Sup}) \rightarrow \text{Koo} = \underline{V}(\text{Sub}, \text{Sup})$$

Zu $(R^* = (\text{Ad}, \text{Adj}, \text{Ex}) \rightarrow \text{Adj} = V(\text{Ad}, \text{Ex}))$ sei noch eine Anmerkung gestattet: Kronthaler (1986, S. 194) weist darauf hin, daß es in der Funktionentheorie im Komplexen "genügt, die Funktion

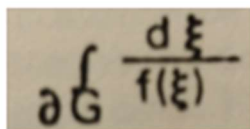

auf dem Rand zu kennen, um sie ganz zu kennen".

Im Falle der Relation

$$P = (\text{PP}, \text{PC}, \text{CP}, \text{CC})$$

gibt es zwei Vermittlungen

$$\text{PC} = \underline{V}(\text{PP}, \text{CC})$$

$$\text{CP} = \underline{V}(\text{CC}, \text{PP}),$$

die wir vermöge Toth (2019c) durch die Relation 0^* (reflektorische Relation)

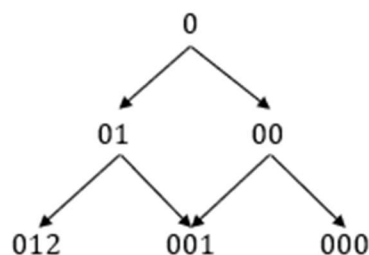

mit $001 = \text{CP}$

definieren können.

Literatur

Bense, Max, Semiotische Prozesse und Systeme. Baden-Baden 1975

Kronthaler, Engelbert, Grundlegung einer Mathematik der Qualitäten. Frankfurt am Main 1986

Kronthaler, Engelbert, Zahl – Zeichen – Begriff. In: Semiosis 65-68, 1992, S. 282-302

Toth, Alfred, Die Hochzeit von Semiotik und Struktur. Klagenfurt 2003

Toth, Alfred, Grundlagen einer Modelltheorie der Ontik I-LVII. In: Electronic Journal for Mathematical Semiotics 2016

Toth, Alfred, Das System der Raumsemiotik. In: Electronic Journal for Mathematical Semiotics, 2017

Toth, Alfred, Einbettungsrelationen topologischer semiotischer Relationen. In: Electronic Journal for Mathematical Semiotics, 2019a

Toth, Alfred, Die Subzeichen der dyadisch-trichotomischen Zeichenrelation und ihre Kenose. In: Electronic Journal for Mathematical Semiotics, 2019b

Toth, Alfred, Zu einer polykontexturalen Systemtheorie. In: Electronic Journal for Mathematical Semiotics, 2019c

Kenogrammatik als Vermittlung zwischen Ontik und Semiotik?

1. In Kronthaler (1986, S. 102) findet sich folgendes Vermittlungsschema zwischen Logik, Mathematik und Kenogrammatik.

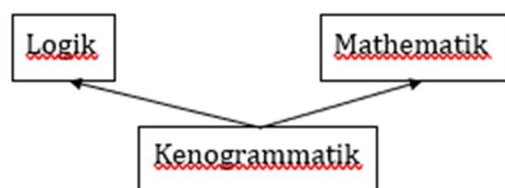

Vermöge der von Günther eingeführten Proömialrelation liegt die Kenogrammatik unterhalb der Wertwissenschaften, ob es sich nun um Wahrheitswerte (Logik), um Zahlwerte (Mathematik) oder um Zeichenwerte (Semiotik) handelt.

2. Im Anschluß an die weiterführenden Erörterungen in Kronthaler (1992) würden wir also für das Verhältnis von Ontik, Semiotik und Kenogrammatik folgendes Vermittlungsschema bekommen.

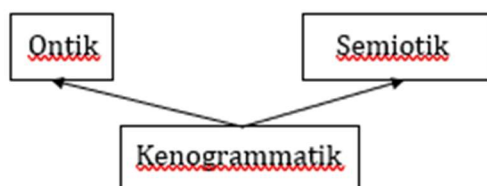

Hierbei stellt allerdings die Kontexturgrenze zwischen Ontik und Semiotik ein Problem dar, denn nach diesem Schema bildet zwar die Kenogrammatik die gemeinsame Basis von Ontik und Semiotik, aber ontische und semiotische Wertbelegung fungieren separat. Dies führt dazu, daß sich keinerlei Relationen zwischen Ontik und Semiotik angeben lassen – in Sonderheit nicht die Isomorphismen, die wir zwischen Toth (2014) und Toth (2019a) in einer langen Reihe von Einzeluntersuchungen herausgearbeitet hatten.

3. Dieses Problem ist umso bedeutsamer, als daß ja zwar nicht zwischen Logik und Mathematik, jedoch zwischen Ontik und Semiotik eine Kontexturgrenze verläuft, und zwar die gleiche, wie diejenige zwischen Objekt und Zeichen, die der logischen Kontexturgrenze in $L = (0, 1)$ isomorph ist (vgl. Toth 2015). Daraus folgt also unmittelbar, daß das Vermittlungsschema der drei Wissenschaften nur das folgende sein kann.

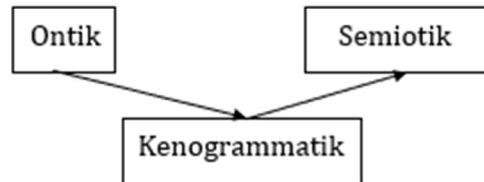

In anderen Worten: Ontische Objekte müssen erst durch Kenose auf ihre kenogrammtische Basis zurückgeführt werden, bevor die entsprechenden Leerformen durch Semiose mit semiotischen Zeichen belegt werden können. DIE KENOGRAMMATIK STELLT SOMIT DIE KONTEXTURALE VERMITTLUNG VON ONTIK UND SEMIOTIK DAR.

Wenn wir diese Erkenntnis mit den Schemata aus Toth (2019b, c) darstellen, bekommen wir

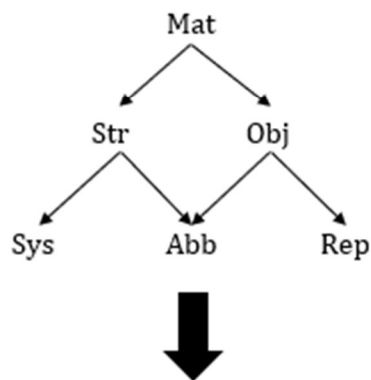

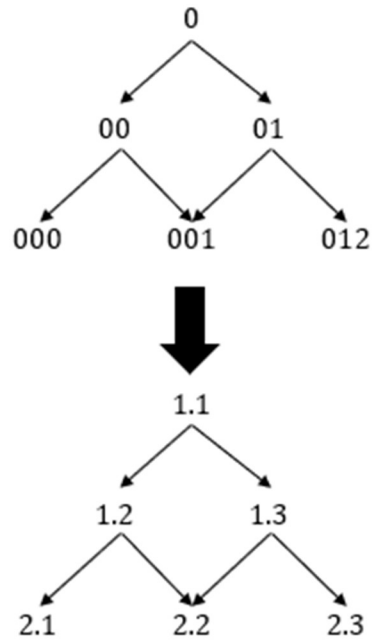

Literatur

Kronthaler, Engelbert Grundlegung einer Mathematik der Qualitäten. Frankfurt am Main 1986

Kronthaler, Engelbert Zahl - Zeichen - Begriff. In: Semiosis 65-68, 1992, S. 282-302

Toth, Alfred, Vollständige und unvollständige ontisch-semiotische Isomorphismen I-III. In: Electronic Journal for Mathematical Semiotics, 2014

Toth, Alfred, Die Logik des Jägers Gracchus. In: Electronic Journal for Mathematical Semiotics, 2015

Toth, Alfred, Semiotisch-ontische Isomorphie beim dyadisch-trichotomischen Zeichenmodell. In: Electronic Journal for Mathematical Semiotics, 2019a

Toth, Alfred, Grundlegung einer polykontexturalen Semiotik. Tucson, AZ, 2019 (= 2019b)

Toth, Alfred, Anfänge einer polykontxturalen Ontik. In: Electronic Journal for Mathematical Semiotics, 2019c

Das vollständige System der kenogrammatischen Vermittlung von Ontik und Semiotik

Zeichen sind immer Zeichen für etwas, sie repräsentieren etwas, das sie selbst nie direkt erreichen. Zeichen und Bezeichnetes sind in dieser Konzeption dichotomisch geschieden als Zeichen/Bezeichnetes, gehören genauso wie Urbild/Abbild, Traum/Wachen verschiedenen Kontexturen an (...). Zeichen sind hier (mindestens) doppelt begrenzt: einmal durch ihre Materialität und Objekthaftigkeit, ferner durch das ihnen ewig transzendente Bezeichnete, das Objekt.

Kronthaler (1992, S. 292)

1. Wie in Toth (2019a) gezeigt wurde, kann das Vermittlungsschema von Kenogrammatik, Ontik und Semiotik nur das folgende sein.

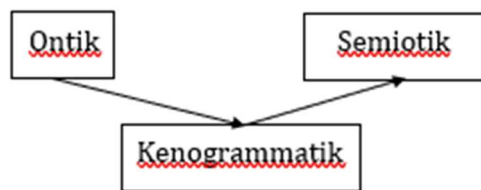

Ontische Objekte müssen somit erst durch Kenose auf ihre kenogrammtische Basis zurückgeführt werden, bevor die entsprechenden Leerformen durch Semiose mit semiotischen Zeichen belegt werden können. DIE KENOGRAMMATIK STELLT SOMIT DIE KONTEXTURALE VERMITTLUNG VON ONTIK UND SEMIOTIK DAR. Wenn wir diese Erkenntnis mit den Schemata aus Toth (2019b, c) darstellen, bekommen wir

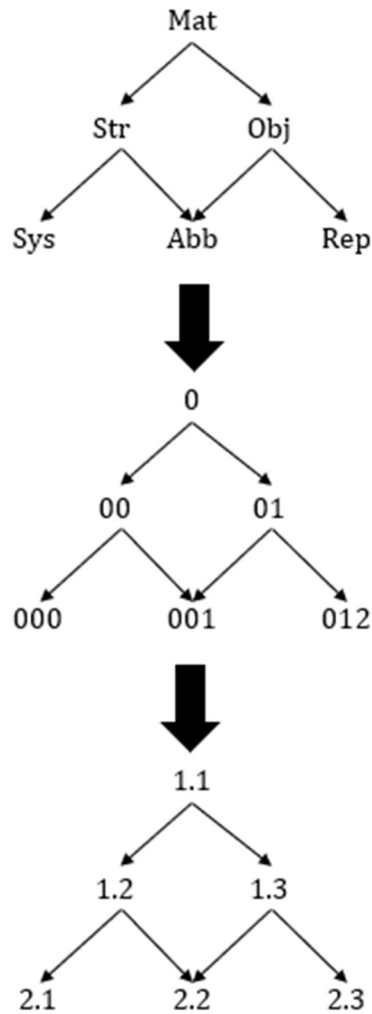

Die Strukturen kenogrammatischer Vermittlung des Systems aller Teilsysteme dyadisch-trichotomischer topologischer Relationen der Ontik und Semiotik, die im folgenden rekonstruiert werden, sind also nichts Geringeres als die qualitativ-mathematische Basis der bereits seit Toth (2014) erarbeiteten Systeme von ontisch-semiotischen Isomorphien. Es handelt sich bei diesen tiefsten erreichbaren Strukturen also um die Aufdeckung der bisher unsichtbaren Brücken über den Abyss des kontexturalen Abbruchs von Objekt und Zeichen. Die Behauptung Hausdorffs, daß zwischen Diesseits und Jenseits keine "Brücke hin- und herüberführe" (Hausdorff 1976, S. 27), ist damit widerlegt.

2.1. (1.1, 2.1)-System

R-System

Ontisches System

(Mat)(Sys) ((Mat))(Sys) (Mat)((Sys)) ((Sys))(Mat) (Sys)((Mat)) ((Mat))((Sys))
 (Mat)(Sys] ((Mat))(Sys] (Mat)((Sys]) ((Sys))(Mat] (Sys)((Mat]) ((Mat))((Sys])
 (Mat)[Sys) ((Mat))[Sys) (Mat)[(Sys)) ((Sys))[Mat) (Sys)[(Mat)) ((Mat))[Sys)
 (Mat)[Sys] ((Mat))[Sys] (Mat)[(Sys)] ((Sys))[Mat] (Sys)[(Mat)] ((Mat))[Sys]

(Mat](Sys) ((Mat)](Sys) (Mat]((Sys)) ((Sys)](Mat) (Sys]((Mat)) ((Mat)]((Sys))
 (Mat](Sys] ((Mat)](Sys] (Mat]((Sys]) ((Sys)](Mat] (Sys]((Mat]) (Mat]((Sys])
 (Mat])[Sys) ((Mat])[Sys) (Mat]([Sys)) ((Sys])[Mat) (Sys]([Mat)) ((Mat])[Sys)
 (Mat])[Sys] ((Mat])[Sys] (Mat]([Sys)] ((Sys])[Mat] (Sys]([Mat)] ((Mat])[Sys]

[Mat)(Sys) [(Mat))(Sys) [Mat)((Sys)) [(Sys))(Mat) [Sys)((Mat)) [(Mat))((Sys))
 [Mat)(Sys] [(Mat))(Sys] [Mat)((Sys]) [(Sys))(Mat] [Sys)((Mat]) [(Mat))((Sys])
 [Mat][Sys) [(Mat)][Sys) [Mat]([Sys)) [(Sys))[Mat) [Sys]([Mat)) [(Mat))[Sys)
 [Mat][Sys] [(Mat))[Sys] [Mat]([Sys)] [(Sys))[Mat] [Sys]([Mat)] [(Mat))[Sys]

[Mat](Sys) [(Mat)](Sys) [Mat]((Sys)) [(Sys)](Mat) [Sys]((Mat)) [(Mat)]((Sys))
 [Mat](Sys] [(Mat)](Sys] [Mat]((Sys]) [(Sys)](Mat] [Sys]((Mat]) [(Mat)]((Sys])
 [Mat][Sys) [(Mat)][Sys) [Mat]([Sys)) [(Sys)](Mat) [Sys]([Mat)) [(Mat)]([Sys))
 [Mat][Sys] [(Mat))[Sys] [Mat]([Sys)] [(Sys)](Mat] [Sys]([Mat)] [(Mat)]([Sys])

Kenogrammatisches System

(o)(ooo) ((o))(ooo) (o)((ooo)) ((ooo))(o) (ooo)((o)) ((o))((ooo))
 (o)(ooo] ((o))(ooo] (o)((ooo]) ((ooo))(o] (ooo)((o]) ((o))((ooo])
 (o)[ooo) ((o))[ooo) (o)[(ooo)) ((ooo))[o] (ooo)[(o)) ((o))[ooo)
 (o)[ooo] ((o))[ooo] (o)[(ooo)] ((ooo))[o] (ooo)[(o)] ((o))[ooo]

(o](ooo) ((o)](ooo) (o]((ooo)) ((ooo)](o) (ooo]((o)) ((o)]((ooo))
 (o](ooo] ((o)](ooo] (o]((ooo]) ((ooo)](o] (ooo]((o]) (o]((ooo])
 (o])[ooo) ((o])[ooo) (o]([ooo)) ((ooo])[o] (ooo]([o)) ((o])[ooo)
 (o])[ooo] ((o])[ooo] (o]([ooo)] ((ooo])[o] (ooo]([o)] ((o])[ooo]

[o)(ooo) [(o))(ooo) [o)((ooo)) [(ooo))(o) [ooo)((o)) [(o))((ooo))
 [o)(ooo] [(o))(ooo] [o)((ooo)] [(ooo))(o] [ooo)((o)] [(o))((ooo)]
 [o][ooo) [(o)][ooo) [o]([ooo)) [(ooo))[o] [ooo]([o)) [(o))[ooo)
 [o][ooo] [(o))[ooo] [o]([ooo)] [(ooo))[o] [ooo]([o)] [(o))[ooo]

[o](ooo) [(o)](ooo) [o]((ooo)) [(ooo)](o) [ooo]((o)) [(o)]((ooo))

$[\circ](\circ\circ\circ)$	$[(\circ)](\circ\circ\circ)$	$[\circ](\circ\circ\circ)$	$[(\circ\circ\circ)](\circ)$	$[\circ\circ\circ](\circ)$	$[(\circ)](\circ\circ\circ)$
$[\circ][\circ\circ\circ]$	$[(\circ)][\circ\circ\circ]$	$[\circ][(\circ\circ\circ)]$	$[(\circ\circ\circ)](\circ)$	$[\circ\circ\circ][(\circ)]$	$[(\circ)][(\circ\circ\circ)]$
$[\circ][\circ\circ\circ]$	$[(\circ)][\circ\circ\circ]$	$[\circ][(\circ\circ\circ)]$	$[(\circ\circ\circ)](\circ)$	$[\circ\circ\circ][(\circ)]$	$[(\circ)][(\circ\circ\circ)]$

Semiotisches System

$(1.1)(2.1)$	$((1.1))(2.1)$	$(1.1)((2.1))$	$((2.1))(1.1)$	$(2.1)((1.1))$	$((1.1))((2.1))$
$(1.1)(2.1)$	$((1.1))(2.1)$	$(1.1)((2.1))$	$((2.1))(1.1)$	$(2.1)((1.1))$	$((1.1))((2.1))$
$(1.1)[2.1]$	$((1.1))[2.1]$	$(1.1)[(2.1)]$	$((2.1))[1.1]$	$(2.1)[(1.1)]$	$((1.1))[2.1]$
$(1.1)[2.1]$	$((1.1))[2.1]$	$(1.1)[(2.1)]$	$((2.1))[1.1]$	$(2.1)[(1.1)]$	$((1.1))[2.1]$

$(1.1)(2.1)$	$((1.1)](2.1)$	$(1.1)((2.1))$	$((2.1)](1.1)$	$(2.1)((1.1))$	$((1.1))((2.1))$
$(1.1)(2.1)$	$((1.1)](2.1)$	$(1.1)((2.1))$	$((2.1)](1.1)$	$(2.1)((1.1))$	$(1.1)((2.1))$
$(1.1)[2.1]$	$((1.1)](2.1)$	$(1.1)[(2.1)]$	$((2.1)](1.1)$	$(2.1)[(1.1)]$	$((1.1)](2.1)$
$(1.1)[2.1]$	$((1.1)](2.1)$	$(1.1)[(2.1)]$	$((2.1)](1.1)$	$(2.1)[(1.1)]$	$((1.1)](2.1)$

$[1.1)(2.1)$	$[(1.1))(2.1)$	$[1.1)((2.1))$	$[(2.1))(1.1)$	$[2.1)((1.1))$	$[(1.1))((2.1))$
$[1.1)(2.1)$	$[(1.1))(2.1)$	$[1.1)((2.1))$	$[(2.1))(1.1)$	$[2.1)((1.1))$	$[(1.1))((2.1))$
$[1.1)[2.1]$	$[(1.1)](2.1)$	$[1.1)[(2.1)]$	$[(2.1)](1.1)$	$[2.1)[(1.1)]$	$[(1.1)](2.1)$
$[1.1)[2.1]$	$[(1.1)](2.1)$	$[1.1)[(2.1)]$	$[(2.1)](1.1)$	$[2.1)[(1.1)]$	$[(1.1)](2.1)$

$[1.1](2.1)$	$[(1.1)](2.1)$	$[1.1)((2.1))$	$[(2.1)](1.1)$	$[2.1)((1.1))$	$[(1.1))((2.1))$
$[1.1](2.1)$	$[(1.1)](2.1)$	$[1.1)((2.1))$	$[(2.1)](1.1)$	$[2.1)((1.1))$	$[(1.1))((2.1))$
$[1.1][2.1]$	$[(1.1)](2.1)$	$[1.1][(2.1)]$	$[(2.1)](1.1)$	$[2.1][(1.1)]$	$[(1.1)](2.1)$
$[1.1][2.1]$	$[(1.1)](2.1)$	$[1.1][(2.1)]$	$[(2.1)](1.1)$	$[2.1][(1.1)]$	$[(1.1)](2.1)$

R*-System

Ontisches System

$(\text{Sys})(\text{Mat})$	$((\text{Sys}))(\text{Mat})$	$(\text{Sys})(\text{Mat})$	$((\text{Mat}))(\text{Sys})$	$(\text{Mat})(\text{Sys})$	$((\text{Sys}))(\text{Mat})$
$(\text{Sys})(\text{Mat})$	$((\text{Sys}))(\text{Mat})$	$(\text{Sys})(\text{Mat})$	$((\text{Mat}))(\text{Sys})$	$(\text{Mat})(\text{Sys})$	$((\text{Sys}))(\text{Mat})$
$(\text{Sys})[\text{Mat}]$	$((\text{Sys}))[\text{Mat}]$	$(\text{Sys})[(\text{Mat})]$	$((\text{Mat}))[\text{Sys}]$	$(\text{Mat})[(\text{Sys})]$	$((\text{Sys}))[(\text{Mat})]$
$(\text{Sys})[\text{Mat}]$	$((\text{Sys}))[\text{Mat}]$	$(\text{Sys})[(\text{Mat})]$	$((\text{Mat}))[\text{Sys}]$	$(\text{Mat})[(\text{Sys})]$	$((\text{Sys}))[(\text{Mat})]$

$(\text{Sys})[\text{Mat}]$	$((\text{Sys})](\text{Mat})$	$(\text{Sys})[(\text{Mat})]$	$((\text{Mat})](\text{Sys})$	$(\text{Mat})[(\text{Sys})]$	$((\text{Sys})](\text{Mat})$
$(\text{Sys})[\text{Mat}]$	$((\text{Sys})](\text{Mat})$	$(\text{Sys})[(\text{Mat})]$	$((\text{Mat})](\text{Sys})$	$(\text{Mat})[(\text{Sys})]$	$(\text{Sys})[(\text{Mat})]$
$(\text{Sys})[\text{Mat}]$	$((\text{Sys})](\text{Mat})$	$(\text{Sys})[(\text{Mat})]$	$((\text{Mat})](\text{Sys})$	$(\text{Mat})[(\text{Sys})]$	$((\text{Sys})](\text{Mat})$
$(\text{Sys})[\text{Mat}]$	$((\text{Sys})](\text{Mat})$	$(\text{Sys})[(\text{Mat})]$	$((\text{Mat})](\text{Sys})$	$(\text{Mat})[(\text{Sys})]$	$((\text{Sys})](\text{Mat})$

$[\text{Sys})(\text{Mat})$	$[(\text{Sys}))(\text{Mat})$	$[\text{Sys})(\text{Mat})$	$[(\text{Mat}))(\text{Sys})$	$[\text{Mat})(\text{Sys})$	$[(\text{Sys}))(\text{Mat})$
$[\text{Sys})(\text{Mat})$	$[(\text{Sys}))(\text{Mat})$	$[\text{Sys})(\text{Mat})$	$[(\text{Mat}))(\text{Sys})$	$[\text{Mat})(\text{Sys})$	$[(\text{Sys}))(\text{Mat})$
$[\text{Sys})[\text{Mat}]$	$[(\text{Sys}))[\text{Mat}]$	$[\text{Sys})[(\text{Mat})]$	$[(\text{Mat}))[\text{Sys}]$	$[\text{Mat})[(\text{Sys})]$	$[(\text{Sys}))[(\text{Mat})]$
$[\text{Sys})[\text{Mat}]$	$[(\text{Sys}))[\text{Mat}]$	$[\text{Sys})[(\text{Mat})]$	$[(\text{Mat}))[\text{Sys}]$	$[\text{Mat})[(\text{Sys})]$	$[(\text{Sys}))[(\text{Mat})]$

[Sys](Mat)	[(Sys)](Mat)	[Sys]((Mat))	[(Mat)](Sys)	[Mat]((Sys))	[(Sys)]((Mat))
[Sys](Mat)	[(Sys)](Mat)	[Sys]((Mat))	[(Mat)](Sys)	[Mat]((Sys))	[(Sys)]((Mat))
[Sys][Mat]	[(Sys)][Mat]	[Sys]((Mat))	[(Mat)][Sys]	[Mat]((Sys))	[(Sys)][(Mat)]
[Sys][Mat]	[(Sys)][Mat]	[Sys]((Mat))	[(Mat)][Sys]	[Mat]((Sys))	[(Sys)][(Mat)]

Kenogrammatisches System

(ooo)(o)	((ooo))(o)	(ooo)((o))	((o))(ooo)	(o)((ooo))	((ooo))((o))
(ooo)[o]	((ooo))[o]	(ooo)[(o)]	((o))[ooo]	(o)[(ooo)]	((ooo))[(o)]
(ooo)[o]	((ooo))[o]	(ooo)[(o)]	((o))[ooo]	(o)[(ooo)]	((ooo))[(o)]
(ooo)[o]	((ooo))[o]	(ooo)[(o)]	((o))[ooo]	(o)[(ooo)]	((ooo))[(o)]

(ooo](o)	((ooo)](o)	(ooo]((o))	((o)](ooo)	(o]((ooo))	((ooo)]((o))
(ooo](o)	((ooo)](o)	(ooo]((o)]	((o)](ooo]	(o]((ooo)]	(ooo]((o)]
(ooo][o)	((ooo)](o)	(ooo][[o))	((o)](ooo)	(o][[ooo))	((ooo)]([o))
(ooo][o]	((ooo)](o)]	(ooo][[o)]	((o)](ooo]	(o][[ooo)]	((ooo)]([o)]

[ooo)(o)	[(ooo))(o)	[ooo]((o))	[(o))(ooo)	[o]((ooo))	[(ooo))((o))
[ooo)(o]	[(ooo))(o]	[ooo]((o)]	[(o))(ooo]	[o]((ooo)]	[(ooo))((o)]
[ooo][o)	[(ooo)](o)	[ooo][[o))	[(o)](ooo)	[o][[ooo))	[(ooo)]([o))
[ooo][o]	[(ooo)](o)]	[ooo][[o)]	[(o)](ooo]	[o][[ooo)]	[(ooo)]([o)]

[ooo](o)	[(ooo)](o)	[ooo]((o))	[(o)](ooo)	[o]((ooo))	[(ooo)]((o))
[ooo](o]	[(ooo)](o)]	[ooo]((o)]	[(o)](ooo]	[o]((ooo)]	[(ooo)]((o)]
[ooo][o)	[(ooo)](o)	[ooo][[o))	[(o)](ooo)	[o][[ooo))	[(ooo)]([o))
[ooo][o]	[(ooo)](o)]	[ooo][[o)]	[(o)](ooo]	[o][[ooo)]	[(ooo)]([o)]

Semiotisches System

(2.1)(1.1)	((2.1))(1.1)	(2.1)((1.1))	((1.1))(2.1)	(1.1)((2.1))	((2.1))((1.1))
(2.1)(1.1]	((2.1))(1.1]	(2.1)((1.1)]	((1.1))(2.1]	(1.1)((2.1)]	((2.1))((1.1)]
(2.1)[1.1)	((2.1))[1.1)	(2.1)[(1.1))	((1.1))[2.1)	(1.1)[(2.1))	((2.1))[1.1))
(2.1)[1.1]	((2.1))[1.1]	(2.1)[(1.1)]	((1.1))[2.1]	(1.1)[(2.1)]	((2.1))[1.1)]

(2.1](1.1)	((2.1)](1.1)	(2.1]((1.1))	((1.1)](2.1)	(1.1]((2.1))	((2.1)]((1.1))
(2.1](1.1]	((2.1)](1.1)]	(2.1]((1.1)]	((1.1)](2.1]	(1.1]((2.1)]	(2.1]((1.1)]
(2.1][1.1)	((2.1)](1.1)	(2.1][[1.1))	((1.1)](2.1)	(1.1][[2.1))	((2.1)]([1.1))
(2.1][1.1]	((2.1)](1.1)]	(2.1][[1.1)]	((1.1)](2.1]	(1.1][[2.1)]	((2.1)]([1.1)]

[2.1)(1.1)	[(2.1))(1.1)	[2.1]((1.1))	[(1.1))(2.1)	[1.1]((2.1))	[(2.1))((1.1))
[2.1)(1.1]	[(2.1))(1.1]	[2.1]((1.1)]	[(1.1))(2.1]	[1.1]((2.1)]	[(2.1))((1.1)]
[2.1][1.1)	[(2.1)](1.1)	[2.1][[1.1))	[(1.1)](2.1)	[1.1][[2.1))	[(2.1)]([1.1))
[2.1][1.1]	[(2.1)](1.1)]	[2.1][[1.1)]	[(1.1)](2.1]	[1.1][[2.1)]	[(2.1)]([1.1)]

[2.1][1.1] [(2.1)][1.1] [2.1][(1.1)] [(1.1)][2.1] [1.1][(2.1)] [(2.1)][(1.1)]

[2.1](1.1) [(2.1)](1.1) [2.1]((1.1)) [(1.1)](2.1) [1.1]((2.1)) [(2.1)]((1.1))

[2.1](1.1) [(2.1)](1.1) [2.1]((1.1)) [(1.1)](2.1) [1.1]((2.1)) [(2.1)]((1.1))

[2.1][1.1] [(2.1)][1.1] [2.1][(1.1)] [(1.1)][2.1] [1.1][(2.1)] [(2.1)][(1.1)]

[2.1][1.1] [(2.1)][1.1] [2.1][(1.1)] [(1.1)][2.1] [1.1][(2.1)] [(2.1)][(1.1)]

2.2. (1.1, 2.2)-System

R-System

Ontisches System

(Mat)(Abb) ((Mat))(Abb) (Mat)((Abb)) ((Abb))(Mat) (Abb)((Mat)) ((Mat))((Abb))

(Mat)(Abb] ((Mat))(Abb] (Mat)((Abb]) ((Abb))(Mat] (Abb)((Mat]) ((Mat))((Abb])

(Mat)[Abb) ((Mat))[Abb) (Mat)[(Abb)) ((Abb))[Mat] (Abb)[(Mat)) ((Mat))[Abb)

(Mat)[Abb] ((Mat))[Abb] (Mat)[(Abb)] ((Abb))[Mat] (Abb)[(Mat)] ((Mat))[Abb]

(Mat](Abb) ((Mat)](Abb) (Mat]((Abb)) ((Abb)](Mat] (Abb]((Mat]) ((Mat)]((Abb))

(Mat](Abb] ((Mat)](Abb] (Mat]((Abb]) ((Abb)](Mat] (Abb]((Mat]) (Mat]((Abb])

(Mat] [Abb) ((Mat] [Abb) (Mat] [(Abb)) ((Abb] [Mat] (Abb] [(Mat)) ((Mat] [(Abb))

(Mat] [Abb] ((Mat] [Abb] (Mat] [(Abb)] ((Abb] [Mat] (Abb] [(Mat)] ((Mat] [(Abb])

[Mat)(Abb) [(Mat))(Abb) [Mat]((Abb)) [(Abb))(Mat] [Abb]((Mat)) [(Mat))((Abb))

[Mat)(Abb] [(Mat))(Abb] [Mat]((Abb]) [(Abb))(Mat] [Abb]((Mat]) [(Mat))((Abb])

[Mat][Abb) [(Mat)][Abb) [Mat] [(Abb)) [(Abb))[Mat] [Abb] [(Mat)) [(Mat)][Abb)

[Mat][Abb] [(Mat)][Abb] [Mat] [(Abb)] [(Abb))[Mat] [Abb] [(Mat)] [(Mat)][Abb]

[Mat](Abb) [(Mat)](Abb) [Mat]((Abb)) [(Abb)](Mat] [Abb]((Mat)) [(Mat)]((Abb))

[Mat](Abb] [(Mat)](Abb] [Mat]((Abb]) [(Abb)](Mat] [Abb]((Mat]) [(Mat)]((Abb])

[Mat][Abb) [(Mat)][Abb) [Mat] [(Abb)) [(Abb)](Mat] [Abb] [(Mat)) [(Mat)][Abb)

[Mat][Abb] [(Mat)][Abb] [Mat] [(Abb)] [(Abb)](Mat] [Abb] [(Mat)] [(Mat)][Abb]

Kenogrammatisches System

(○)(○○△) ((○))(○○△) (○)((○○△)) ((○○△))(○) (○○△)((○)) ((○))((○○△))

(○)(○○△] ((○))(○○△] (○)((○○△]) ((○○△))(○] (○○△)((○]) ((○))((○○△])

(○)[○○△) ((○))[○○△) (○)[(○○△)) ((○○△))[○] (○○△)[(○)) ((○))[○○△))

(○)[○○△] ((○))[○○△] (○)[(○○△)] ((○○△))[○] (○○△)[(○)] ((○))[○○△]

(○](○○△) ((○)](○○△) (○]((○○△)) ((○○△)](○) (○○△]((○)) ((○)]((○○△))

(○](○○△] ((○)](○○△] (○]((○○△]) ((○○△)](○] (○○△]((○]) (○]((○○△])

(○][○○△) ((○)][○○△) (○][(○○△)) ((○○△)][○] (○○△][(○)) ((○)][○○△))

(○][○○△] ((○)][○○△] (○][(○○△)] ((○○△)][○] (○○△][(○)] ((○)][○○△]

$(\circ)[\circ\circ\Delta]$	$((\circ))[\circ\circ\Delta]$	$(\circ)[(\circ\circ\Delta)]$	$((\circ\circ\Delta))[\circ]$	$(\circ\circ\Delta)[(\circ)]$	$((\circ))[(\circ\circ\Delta)]$
$[\circ](\circ\circ\Delta)$	$[(\circ))(\circ\circ\Delta)$	$[\circ](\circ\circ\Delta)$	$[(\circ\circ\Delta))(\circ)$	$[\circ\circ\Delta)((\circ))$	$[(\circ))((\circ\circ\Delta))$
$[\circ](\circ\circ\Delta)$	$[(\circ))(\circ\circ\Delta)$	$[\circ](\circ\circ\Delta)$	$[(\circ\circ\Delta))(\circ)$	$[\circ\circ\Delta)((\circ))$	$[(\circ))((\circ\circ\Delta))$
$[\circ][\circ\circ\Delta]$	$[(\circ))[\circ\circ\Delta]$	$[\circ][(\circ\circ\Delta)]$	$[(\circ\circ\Delta)][\circ]$	$[\circ\circ\Delta][(\circ)]$	$[(\circ))[(\circ\circ\Delta)]$
$[\circ][\circ\circ\Delta]$	$[(\circ))[\circ\circ\Delta]$	$[\circ][(\circ\circ\Delta)]$	$[(\circ\circ\Delta)][\circ]$	$[\circ\circ\Delta][(\circ)]$	$[(\circ))[(\circ\circ\Delta)]$
$[\circ](\circ\circ\Delta)$	$[(\circ))(\circ\circ\Delta)$	$[\circ](\circ\circ\Delta)$	$[(\circ\circ\Delta)](\circ)$	$[\circ\circ\Delta)((\circ))$	$[(\circ))((\circ\circ\Delta))$
$[\circ](\circ\circ\Delta)$	$[(\circ))(\circ\circ\Delta)$	$[\circ](\circ\circ\Delta)$	$[(\circ\circ\Delta)](\circ)$	$[\circ\circ\Delta)((\circ))$	$[(\circ))((\circ\circ\Delta))$
$[\circ][\circ\circ\Delta]$	$[(\circ))[\circ\circ\Delta]$	$[\circ][(\circ\circ\Delta)]$	$[(\circ\circ\Delta)][\circ]$	$[\circ\circ\Delta][(\circ)]$	$[(\circ))[(\circ\circ\Delta)]$
$[\circ][\circ\circ\Delta]$	$[(\circ))[\circ\circ\Delta]$	$[\circ][(\circ\circ\Delta)]$	$[(\circ\circ\Delta)][\circ]$	$[\circ\circ\Delta][(\circ)]$	$[(\circ))[(\circ\circ\Delta)]$

Semiotisches System

$(1.1)(2.2)$	$((1.1))(2.2)$	$(1.1)((2.2))$	$((2.2))(1.1)$	$(2.2)((1.1))$	$((1.1))((2.2))$
$(1.1)(2.2)$	$((1.1))(2.2)$	$(1.1)((2.2))$	$((2.2))(1.1)$	$(2.2)((1.1))$	$((1.1))((2.2))$
$(1.1)[2.2]$	$((1.1))[2.2]$	$(1.1)[(2.2)]$	$((2.2))[1.1]$	$(2.2)[(1.1)]$	$((1.1))[2.2]$
$(1.1)[2.2]$	$((1.1))[2.2]$	$(1.1)[(2.2)]$	$((2.2))[1.1]$	$(2.2)[(1.1)]$	$((1.1))[2.2]$
$(1.1)(2.2)$	$((1.1)](2.2)$	$(1.1)((2.2))$	$((2.2)](1.1)$	$(2.2)((1.1))$	$((1.1))((2.2))$
$(1.1)(2.2)$	$((1.1)](2.2)$	$(1.1)((2.2))$	$((2.2)](1.1)$	$(2.2)((1.1))$	$(1.1)((2.2))$
$(1.1)[2.2]$	$((1.1)](2.2)$	$(1.1)[(2.2)]$	$((2.2)](1.1)$	$(2.2)[(1.1)]$	$((1.1))[2.2]$
$(1.1)[2.2]$	$((1.1)](2.2)$	$(1.1)[(2.2)]$	$((2.2)](1.1)$	$(2.2)[(1.1)]$	$((1.1))[2.2]$
$[1.1)(2.2)$	$[(1.1))(2.2)$	$[1.1)((2.2))$	$[(2.2))(1.1)$	$[2.2)((1.1))$	$[(1.1))((2.2))$
$[1.1)(2.2)$	$[(1.1))(2.2)$	$[1.1)((2.2))$	$[(2.2))(1.1)$	$[2.2)((1.1))$	$[(1.1))((2.2))$
$[1.1][2.2]$	$[(1.1)][2.2]$	$[1.1][2.2]$	$[(2.2)][1.1]$	$[2.2][1.1]$	$[(1.1)][2.2]$
$[1.1][2.2]$	$[(1.1)][2.2]$	$[1.1][2.2]$	$[(2.2)][1.1]$	$[2.2][1.1]$	$[(1.1)][2.2]$
$[1.1)(2.2)$	$[(1.1)](2.2)$	$[1.1)((2.2))$	$[(2.2)](1.1)$	$[2.2)((1.1))$	$[(1.1)](2.2)$
$[1.1)(2.2)$	$[(1.1)](2.2)$	$[1.1)((2.2))$	$[(2.2)](1.1)$	$[2.2)((1.1))$	$[(1.1)](2.2)$
$[1.1][2.2]$	$[(1.1)](2.2)$	$[1.1][2.2]$	$[(2.2)][1.1]$	$[2.2][1.1]$	$[(1.1)][2.2]$
$[1.1][2.2]$	$[(1.1)](2.2)$	$[1.1][2.2]$	$[(2.2)][1.1]$	$[2.2][1.1]$	$[(1.1)][2.2]$

R*-System

Ontisches System

$(Abb)(Mat)$	$((Abb))(Mat)$	$(Abb)((Mat))$	$((Mat))(Abb)$	$(Mat)((Abb))$	$((Abb))((Mat))$
$(Abb)(Mat)$	$((Abb))(Mat)$	$(Abb)((Mat))$	$((Mat))(Abb)$	$(Mat)((Abb))$	$((Abb))((Mat))$
$(Abb)[Mat]$	$((Abb))[Mat]$	$(Abb)[(Mat)]$	$((Mat))[Abb]$	$(Mat)[(Abb)]$	$((Abb))[Mat]$
$(Abb)[Mat]$	$((Abb))[Mat]$	$(Abb)[(Mat)]$	$((Mat))[Abb]$	$(Mat)[(Abb)]$	$((Abb))[Mat]$
$(Abb)](Mat)$	$((Abb)](Mat)$	$(Abb)]((Mat))$	$((Mat)](Abb)$	$(Mat)]((Abb))$	$((Abb)]((Mat))$

(Abb)(Mat) ((Abb))(Mat) (Abb)((Mat)) ((Mat))(Abb) (Mat)((Abb)) (Abb)((Mat))
 (Abb)[Mat] ((Abb))[Mat] (Abb)[(Mat)] ((Mat))[Abb] (Mat)[(Abb)] ((Abb))[Mat]
 (Abb)[Mat] ((Abb))[Mat] (Abb)[(Mat)] ((Mat))[Abb] (Mat)[(Abb)] ((Abb))[Mat]

[Abb)(Mat) [(Abb))(Mat) [Abb)((Mat)) [(Mat))(Abb) [Mat)((Abb)) [(Abb))(Mat)
 [Abb)(Mat) [(Abb))(Mat) [Abb)((Mat)) [(Mat))(Abb) [Mat)((Abb)) [(Abb))(Mat)
 [Abb][Mat] [(Abb)][Mat] [Abb]([Mat]) [(Mat)][Abb] [Mat]([Abb]) [(Abb)][Mat]
 [Abb][Mat] [(Abb)][Mat] [Abb]([Mat]) [(Mat)][Abb] [Mat]([Abb]) [(Abb)][Mat]

[Abb](Mat) [(Abb)](Mat) [Abb]((Mat)) [(Mat)](Abb) [Mat]((Abb)) [(Abb)](Mat)
 [Abb](Mat) [(Abb)](Mat) [Abb]((Mat)) [(Mat)](Abb) [Mat]((Abb)) [(Abb)](Mat)
 [Abb][Mat] [(Abb)][Mat] [Abb]([Mat]) [(Mat)][Abb] [Mat]([Abb]) [(Abb)][Mat]
 [Abb][Mat] [(Abb)][Mat] [Abb]([Mat]) [(Mat)][Abb] [Mat]([Abb]) [(Abb)][Mat]

Kenogrammatisches System

(ooΔ)(o) ((ooΔ))(o) (ooΔ)((o)) ((o))(ooΔ) (o)((ooΔ)) ((ooΔ))((o))
 (ooΔ)[o] ((ooΔ))[o] (ooΔ)[(o)] ((o))[ooΔ] (o)[(ooΔ)] ((ooΔ))[(o)]
 (ooΔ)[o] ((ooΔ))[o] (ooΔ)[(o)] ((o))[ooΔ] (o)[(ooΔ)] ((ooΔ))[(o)]
 (ooΔ)[o] ((ooΔ))[o] (ooΔ)[(o)] ((o))[ooΔ] (o)[(ooΔ)] ((ooΔ))[(o)]

(ooΔ](o) ((ooΔ)](o) (ooΔ]((o)) ((o)](ooΔ) (o)]((ooΔ)) ((ooΔ)]((o))
 (ooΔ][o] ((ooΔ)](o) (ooΔ]((o)) ((o)](ooΔ) (o)]((ooΔ)) ((ooΔ)]((o))
 (ooΔ][o] ((ooΔ)](o) (ooΔ]((o)) ((o)](ooΔ) (o)]((ooΔ)) ((ooΔ)]((o))
 (ooΔ][o] ((ooΔ)](o) (ooΔ]((o)) ((o)](ooΔ) (o)]((ooΔ)) ((ooΔ)]((o))

[ooΔ)(o) [(ooΔ))(o) [ooΔ]((o)) [(o)](ooΔ) [o]((ooΔ)) [(ooΔ))((o))
 [ooΔ)(o) [(ooΔ))(o) [ooΔ]((o)) [(o)](ooΔ) [o]((ooΔ)) [(ooΔ))((o))
 [ooΔ][o] [(ooΔ)](o) [ooΔ]((o)) [(o)](ooΔ) [o]((ooΔ)) [(ooΔ))[(o)]
 [ooΔ][o] [(ooΔ)](o) [ooΔ]((o)) [(o)](ooΔ) [o]((ooΔ)) [(ooΔ))[(o)]

[ooΔ](o) [(ooΔ)](o) [ooΔ]((o)) [(o)](ooΔ) [o]((ooΔ)) [(ooΔ)]((o))
 [ooΔ](o) [(ooΔ)](o) [ooΔ]((o)) [(o)](ooΔ) [o]((ooΔ)) [(ooΔ)]((o))
 [ooΔ][o] [(ooΔ)](o) [ooΔ]((o)) [(o)](ooΔ) [o]((ooΔ)) [(ooΔ)]((o))
 [ooΔ][o] [(ooΔ)](o) [ooΔ]((o)) [(o)](ooΔ) [o]((ooΔ)) [(ooΔ)]((o))

Semiotisches System

(2.2)(1.1) ((2.2))(1.1) (2.2)((1.1)) ((1.1))(2.2) (1.1)((2.2)) ((2.2))((1.1))

(2.2)(1.1)	((2.2))(1.1)	(2.2)((1.1))	((1.1))(2.2)	(1.1)((2.2))	((2.2))((1.1))
(2.2)[1.1]	((2.2))[1.1]	(2.2)[(1.1)]	((1.1))[2.2]	(1.1)[(2.2)]	((2.2))[1.1]
(2.2)](1.1)	((2.2)](1.1)	(2.2)]((1.1))	((1.1)](2.2)	(1.1)]((2.2))	((2.2)]((1.1))
(2.2)](1.1)	((2.2)](1.1)	(2.2)]((1.1))	((1.1)](2.2)	(1.1)]((2.2))	(2.2)]((1.1))
(2.2)](1.1)	((2.2)](1.1)	(2.2)]((1.1))	((1.1)](2.2)	(1.1)]((2.2))	((2.2)](1.1))
(2.2)](1.1)	((2.2)](1.1)	(2.2)]((1.1))	((1.1)](2.2)	(1.1)]((2.2))	((2.2)](1.1))
[2.2)(1.1)	[(2.2))(1.1)	[2.2)((1.1))	[(1.1))(2.2)	[1.1)((2.2))	[(2.2))((1.1))
[2.2)(1.1)	[(2.2))(1.1)	[2.2)((1.1))	[(1.1))(2.2)	[1.1)((2.2))	[(2.2))((1.1))
[2.2)[1.1]	[(2.2)][1.1]	[2.2)[(1.1)]	[(1.1)][2.2]	[1.1][(2.2)]	[(2.2)][1.1]
[2.2)[1.1]	[(2.2)][1.1]	[2.2)[(1.1)]	[(1.1)][2.2]	[1.1][(2.2)]	[(2.2)][1.1]
[2.2)](1.1)	[(2.2)](1.1)	[2.2)]((1.1))	[(1.1)](2.2)	[1.1)]((2.2))	[(2.2)]((1.1))
[2.2)](1.1)	[(2.2)](1.1)	[2.2)]((1.1))	[(1.1)](2.2)	[1.1)]((2.2))	[(2.2)]((1.1))
[2.2)](1.1)	[(2.2)](1.1)	[2.2)]((1.1))	[(1.1)](2.2)	[1.1)]((2.2))	[(2.2)]((1.1))
[2.2)](1.1)	[(2.2)](1.1)	[2.2)]((1.1))	[(1.1)](2.2)	[1.1)]((2.2))	[(2.2)]((1.1))

2.3. (1.1, 2.3)-System

R-System

Ontisches System

(Mat)(Rep)	((Mat))(Rep)	(Mat)((Rep))	((Rep))(Mat)	(Rep)((Mat))	((Mat))((Rep))
(Mat)(Rep]	((Mat))(Rep]	(Mat)((Rep)]	((Rep))(Mat]	(Rep)((Mat)]	((Mat))((Rep)]
(Mat)[Rep)	((Mat))[Rep)	(Mat)[(Rep))	((Rep))[Mat)	(Rep)[(Mat))	((Mat))[Rep))
(Mat)[Rep]	((Mat))[Rep]	(Mat)[(Rep)]	((Rep))[Mat]	(Rep)[(Mat)]	((Mat))[Rep]
(Mat)](Rep)	((Mat)](Rep)	(Mat)]((Rep))	((Rep)](Mat)	(Rep)]((Mat))	((Mat)]((Rep))
(Mat)](Rep]	((Mat)](Rep]	(Mat)]((Rep)]	((Rep)](Mat]	(Rep)]((Mat)]	(Mat)]((Rep)]
(Mat)](Rep)	((Mat)](Rep)	(Mat)]((Rep))	((Rep)](Mat)	(Rep)]((Mat))	((Mat)](Rep))
(Mat)](Rep]	((Mat)](Rep]	(Mat)]((Rep)]	((Rep)](Mat]	(Rep)]((Mat)]	((Mat)](Rep)]
[Mat)(Rep)	[(Mat))(Rep)	[Mat)((Rep))	[(Rep))(Mat)	[Rep)((Mat))	[(Mat))((Rep))
[Mat)(Rep]	[(Mat))(Rep]	[Mat)((Rep)]	[(Rep))(Mat]	[Rep)((Mat)]	[(Mat))((Rep)]
[Mat)[Rep)	[(Mat))[Rep)	[Mat)[(Rep))	[(Rep))[Mat)	[Rep)[(Mat))	[(Mat))[Rep))
[Mat)[Rep]	[(Mat))[Rep]	[Mat)[(Rep)]	[(Rep))[Mat]	[Rep)[(Mat)]	[(Mat))[Rep]
[Mat)](Rep)	[(Mat)](Rep)	[Mat)]((Rep))	[(Rep)](Mat)	[Rep)]((Mat))	[(Mat)]((Rep))
[Mat)](Rep]	[(Mat)](Rep]	[Mat)]((Rep)]	[(Rep)](Mat]	[Rep)]((Mat)]	[(Mat)]((Rep)]
[Mat)](Rep)	[(Mat)](Rep)	[Mat)]((Rep))	[(Rep)](Mat)	[Rep)]((Mat))	[(Mat)](Rep))
[Mat)](Rep]	[(Mat)](Rep]	[Mat)]((Rep)]	[(Rep)](Mat]	[Rep)]((Mat)]	[(Mat)](Rep)]

Kenogrammatisches System

(○)(○△□)	((○))(○△□)	(○)((○△□))	((○△□))(○)	(○△□)((○))	((○))((○△□))
(○)(○△□]	((○))(○△□]	(○)((○△□])	((○△□))(○]	(○△□)((○)]	((○))((○△□])
(○)[○△□)	((○))[○△□)	(○)[(○△□))	((○△□))[○)	(○△□)[(○))	((○))[○△□)
(○)[○△□]	((○))[○△□]	(○)[(○△□)]	((○△□))[○]	(○△□)[(○)]	((○))[○△□]
(○)](○△□)	((○)](○△□)	(○)]((○△□))	((○△□)](○)	(○△□)]((○))	((○)]((○△□))
(○)](○△□]	((○)](○△□]	(○)]((○△□])	((○△□)](○]	(○△□)]((○)]	(○)]((○△□])
(○)](○△□)	((○)](○△□)	(○)][(○△□))	((○△□)](○)	(○△□)][(○))	((○)][(○△□))
(○)](○△□]	((○)](○△□]	(○)][(○△□)]	((○△□)](○]	(○△□)][(○)]	((○)][(○△□)]
[○)(○△□)	[(○))(○△□)	[○)((○△□))	[(○△□))(○)	[○△□)((○))	[(○))((○△□))
[○)(○△□]	[(○))(○△□]	[○)((○△□])	[(○△□))(○]	[○△□)((○)]	[(○))((○△□])
[○)[○△□)	[(○))[○△□)	[○)[(○△□))	[(○△□))[○)	[○△□)[(○))	[(○))[○△□)
[○)[○△□]	[(○))[○△□]	[○)[(○△□)]	[(○△□))[○]	[○△□)[(○)]	[(○))[○△□]
[○)](○△□)	[(○)](○△□)	[○)]((○△□))	[(○△□)](○)	[○△□)]((○))	[(○)]((○△□))
[○)](○△□]	[(○)](○△□]	[○)]((○△□])	[(○△□)](○]	[○△□)]((○)]	[(○)]((○△□])
[○)](○△□)	[(○)](○△□)	[○)][(○△□))	[(○△□)](○)	[○△□)][(○))	[(○)][(○△□))
[○)](○△□]	[(○)](○△□]	[○)][(○△□)]	[(○△□)](○]	[○△□)][(○)]	[(○)][(○△□)]

Semiotisches System

(1.1)(2.3)	((1.1))(2.3)	(1.1)((2.3))	((2.3))(1.1)	(2.3)((1.1))	((1.1))((2.3))
(1.1)(2.3]	((1.1))(2.3]	(1.1)((2.3])	((2.3))(1.1]	(2.3)((1.1)]	((1.1))((2.3])
(1.1)[2.3)	((1.1))[2.3)	(1.1)[(2.3))	((2.3))[1.1)	(2.3)[(1.1))	((1.1))[2.3)
(1.1)[2.3]	((1.1))[2.3]	(1.1)[(2.3)]	((2.3))[1.1]	(2.3)[(1.1)]	((1.1))[2.3]
(1.1)](2.3)	((1.1)](2.3)	(1.1)]((2.3))	((2.3)](1.1)	(2.3)]((1.1))	((1.1)](2.3))
(1.1)](2.3]	((1.1)](2.3]	(1.1)]((2.3])	((2.3)](1.1]	(2.3)]((1.1)]	(1.1)](2.3])
(1.1)](2.3)	((1.1)](2.3)	(1.1)][(2.3))	((2.3)](1.1)	(2.3)][(1.1))	((1.1)][(2.3))
(1.1)](2.3]	((1.1)](2.3]	(1.1)][(2.3)]	((2.3)](1.1]	(2.3)][(1.1)]	((1.1)][(2.3)]
[1.1)(2.3)	[(1.1))(2.3)	[1.1)((2.3))	[(2.3))(1.1)	[2.3)((1.1))	[(1.1))((2.3))
[1.1)(2.3]	[(1.1))(2.3]	[1.1)((2.3])	[(2.3))(1.1]	[2.3)((1.1)]	[(1.1))((2.3])
[1.1)[2.3)	[(1.1))[2.3)	[1.1)[(2.3))	[(2.3))[1.1)	[2.3)[(1.1))	[(1.1))[2.3)
[1.1)[2.3]	[(1.1))[2.3]	[1.1)[(2.3)]	[(2.3))[1.1]	[2.3)[(1.1)]	[(1.1))[2.3]
[1.1)](2.3)	[(1.1)](2.3)	[1.1)]((2.3))	[(2.3)](1.1)	[2.3)]((1.1))	[(1.1)](2.3))
[1.1)](2.3]	[(1.1)](2.3]	[1.1)]((2.3])	[(2.3)](1.1]	[2.3)]((1.1)]	[(1.1)](2.3])
[1.1)](2.3)	[(1.1)](2.3)	[1.1)][(2.3))	[(2.3)](1.1)	[2.3)][(1.1))	[(1.1)][(2.3))
[1.1)](2.3]	[(1.1)](2.3]	[1.1)][(2.3)]	[(2.3)](1.1]	[2.3)][(1.1)]	[(1.1)][(2.3)]

[1.1][2.3] [(1.1)][2.3] [1.1][(2.3)] [(2.3)][1.1] [2.3][(1.1)] [(1.1)][(2.3)].

R*-System

Ontisches System

(Rep)(Mat) ((Rep))(Mat) (Rep)((Mat)) ((Mat))(Rep) (Mat)((Rep)) ((Rep))((Mat))
 (Rep)(Mat] ((Rep))(Mat] (Rep)((Mat]) ((Mat))(Rep] (Mat)((Rep]) ((Rep))((Mat])
 (Rep)[Mat) ((Rep))[Mat) (Rep)[(Mat)) ((Mat))[Rep] (Mat)[(Rep)) ((Rep))[Mat))
 (Rep)[Mat] ((Rep))[Mat] (Rep)[(Mat)] ((Mat))[Rep] (Mat)[(Rep)] ((Rep))[Mat]

(Rep](Mat) ((Rep)](Mat) (Rep]((Mat)) ((Mat)](Rep) (Mat]((Rep)) ((Rep)]((Mat))
 (Rep](Mat] ((Rep)](Mat] (Rep]((Mat]) ((Mat)](Rep] (Mat]((Rep]) (Rep]((Mat])
 (Rep][Mat) ((Rep)][Mat) (Rep][Mat)) ((Mat)][Rep] (Mat][Rep)) ((Rep)][Mat))
 (Rep][Mat] ((Rep)][Mat] (Rep][Mat)] ((Mat)][Rep] (Mat][Rep)] ((Rep)][Mat]

[Rep)(Mat) [(Rep)))(Mat) [Rep)((Mat)) [(Mat))(Rep] [Mat)((Rep)) [(Rep))((Mat))
 [Rep)(Mat] [(Rep)))(Mat] [Rep)((Mat]) [(Mat))(Rep] [Mat)((Rep)] [(Rep))((Mat)]
 [Rep][Mat) [(Rep))[Mat) [Rep][Mat)) [(Mat))[Rep] [Mat][Rep)) [(Rep))[Mat))
 [Rep][Mat] [(Rep))[Mat] [Rep][Mat)] [(Mat))[Rep] [Mat][Rep)] [(Rep))[Mat]

[Rep](Mat) [(Rep)](Mat) [Rep]((Mat)) [(Mat)](Rep) [Mat]((Rep)) [(Rep)]((Mat))
 [Rep](Mat] [(Rep)](Mat] [Rep]((Mat]) [(Mat)](Rep] [Mat]((Rep]) [(Rep)]((Mat])
 [Rep][Mat) [(Rep)][Mat) [Rep][Mat)) [(Mat)][Rep] [Mat][Rep)) [(Rep)][Mat))
 [Rep][Mat] [(Rep)][Mat] [Rep][Mat)] [(Mat)][Rep] [Mat][Rep)] [(Rep)][Mat]

Kenogrammatisches System

(◊Δ□)(○) ((◊Δ□))(○) (◊Δ□)((○)) ((○))(◊Δ□) (○)((◊Δ□)) ((◊Δ□))((○))
 (◊Δ□)(○] ((◊Δ□))(○] (◊Δ□)((○]) ((○))(◊Δ□] (○)((◊Δ□]) ((◊Δ□))((○])
 (◊Δ□)[○) ((◊Δ□))[○) (◊Δ□)[(○)) ((○))[◊Δ□] (○)[(◊Δ□)) ((◊Δ□))[○))
 (◊Δ□)[○] ((◊Δ□))[○] (◊Δ□)[(○)] ((○))[◊Δ□] (○)[(◊Δ□)] ((◊Δ□))[○]

(◊Δ□](○) ((◊Δ□)](○) (◊Δ□]((○)) ((○)](◊Δ□) (○]((◊Δ□)) ((◊Δ□)]((○))
 (◊Δ□](○] ((◊Δ□)](○] (◊Δ□]((○]) ((○)](◊Δ□] (○]((◊Δ□]) (◊Δ□]((○])
 (◊Δ□][○) ((◊Δ□)][○) (◊Δ□][○)) ((○)][◊Δ□] (○)[(◊Δ□)) ((◊Δ□)][○))
 (◊Δ□][○] ((◊Δ□)][○] (◊Δ□][○)] ((○)][◊Δ□] (○)[(◊Δ□)] ((◊Δ□)][○]

[◊Δ□)(○) [(◊Δ□)))(○) [◊Δ□)((○)) [(○))(◊Δ□] [○)((◊Δ□)) [(◊Δ□))((○))
 [◊Δ□)(○] [(◊Δ□)))(○] [◊Δ□)((○)] [(○))(◊Δ□] [○)((◊Δ□)] [(◊Δ□))((○)]
 [◊Δ□)[○) [(◊Δ□))[○) [◊Δ□)[(○)) [(○))[◊Δ□] [○)[(◊Δ□)) [(◊Δ□))[○))
 [◊Δ□)[○] [(◊Δ□))[○] [◊Δ□)[(○)] [(○))[◊Δ□] [○)[(◊Δ□)] [(◊Δ□))[○]

$[\circ\Delta\Box](\circ)$	$[(\circ\Delta\Box)](\circ)$	$[\circ\Delta\Box](\circ\circ)$	$[(\circ)](\circ\Delta\Box)$	$[\circ](\circ\Delta\Box)$	$[(\circ\Delta\Box)](\circ\circ)$
$[\circ\Delta\Box](\circ)$	$[(\circ\Delta\Box)](\circ)$	$[\circ\Delta\Box](\circ\circ)$	$[(\circ)](\circ\Delta\Box)$	$[\circ](\circ\Delta\Box)$	$[(\circ\Delta\Box)](\circ\circ)$
$[\circ\Delta\Box][\circ]$	$[(\circ\Delta\Box)][\circ]$	$[\circ\Delta\Box][\circ\circ]$	$[(\circ)][\circ\Delta\Box]$	$[\circ][\circ\Delta\Box]$	$[(\circ\Delta\Box)][\circ\circ]$
$[\circ\Delta\Box][\circ]$	$[(\circ\Delta\Box)][\circ]$	$[\circ\Delta\Box][\circ\circ]$	$[(\circ)][\circ\Delta\Box]$	$[\circ][\circ\Delta\Box]$	$[(\circ\Delta\Box)][\circ\circ]$

Semiotisches System

$(2.3)(1.1)$	$((2.3))(1.1)$	$(2.3)((1.1))$	$((1.1))(2.3)$	$(1.1)((2.3))$	$((2.3))((1.1))$
$(2.3)(1.1)$	$((2.3))(1.1)$	$(2.3)((1.1))$	$((1.1))(2.3)$	$(1.1)((2.3))$	$((2.3))((1.1))$
$(2.3)[1.1]$	$((2.3))[1.1]$	$(2.3)[(1.1)]$	$((1.1))[2.3]$	$(1.1)[(2.3)]$	$((2.3))[(1.1)]$
$(2.3)[1.1]$	$((2.3))[1.1]$	$(2.3)[(1.1)]$	$((1.1))[2.3]$	$(1.1)[(2.3)]$	$((2.3))[(1.1)]$
$(2.3](1.1)$	$((2.3)](1.1)$	$(2.3]((1.1))$	$((1.1)](2.3)$	$(1.1]((2.3))$	$((2.3)]((1.1))$
$(2.3](1.1)$	$((2.3)](1.1)$	$(2.3]((1.1))$	$((1.1)](2.3)$	$(1.1]((2.3))$	$(2.3]((1.1))$
$(2.3][1.1]$	$((2.3)][1.1]$	$(2.3][(1.1)]$	$((1.1)][2.3]$	$(1.1][(2.3)]$	$((2.3)][(1.1)]$
$(2.3][1.1]$	$((2.3)][1.1]$	$(2.3][(1.1)]$	$((1.1)][2.3]$	$(1.1][(2.3)]$	$((2.3)][(1.1)]$
$[2.3)(1.1)$	$[(2.3))(1.1)$	$[2.3)((1.1))$	$[(1.1))(2.3)$	$[1.1)((2.3))$	$[(2.3))((1.1))$
$[2.3)(1.1)$	$[(2.3))(1.1)$	$[2.3)((1.1))$	$[(1.1))(2.3)$	$[1.1)((2.3))$	$[(2.3))((1.1))$
$[2.3][1.1]$	$[(2.3)][1.1]$	$[2.3][(1.1)]$	$[(1.1)][2.3]$	$[1.1][(2.3)]$	$[(2.3)][(1.1)]$
$[2.3][1.1]$	$[(2.3)][1.1]$	$[2.3][(1.1)]$	$[(1.1)][2.3]$	$[1.1][(2.3)]$	$[(2.3)][(1.1)]$
$[2.3](1.1)$	$[(2.3)](1.1)$	$[2.3]((1.1))$	$[(1.1)](2.3)$	$[1.1]((2.3))$	$[(2.3)]((1.1))$
$[2.3](1.1)$	$[(2.3)](1.1)$	$[2.3]((1.1))$	$[(1.1)](2.3)$	$[1.1]((2.3))$	$[(2.3)]((1.1))$
$[2.3][1.1]$	$[(2.3)][1.1]$	$[2.3][(1.1)]$	$[(1.1)][2.3]$	$[1.1][(2.3)]$	$[(2.3)][(1.1)]$
$[2.3][1.1]$	$[(2.3)][1.1]$	$[2.3][(1.1)]$	$[(1.1)][2.3]$	$[1.1][(2.3)]$	$[(2.3)][(1.1)]$

2.4. (1.2, 2.1)-System

R-System

Ontisches System

$(Str)(Sys)$	$((Str))(Sys)$	$(Str)((Sys))$	$((Sys))(Str)$	$(Sys)((Str))$	$((Str))((Sys))$
$(Str)(Sys]$	$((Str))(Sys]$	$(Str)((Sys])$	$((Sys))(Str]$	$(Sys)((Str])$	$((Str))((Sys])$
$(Str)[Sys)$	$((Str))[Sys)$	$(Str)[(Sys))$	$((Sys))[Str)$	$(Sys)[(Str))$	$((Str))[(Sys))$
$(Str)[Sys]$	$((Str))[Sys]$	$(Str)[(Sys)]$	$((Sys))[Str]$	$(Sys)[(Str)]$	$((Str))[(Sys)]$
$(Str](Sys)$	$((Str)](Sys)$	$(Str]((Sys))$	$((Sys)](Str)$	$(Sys]((Str))$	$((Str)]((Sys))$
$(Str](Sys]$	$((Str)](Sys]$	$(Str]((Sys])$	$((Sys)](Str]$	$(Sys]((Str])$	$(Str]((Sys])$
$(Str][Sys)$	$((Str)][Sys)$	$(Str][(Sys))$	$((Sys)][Str)$	$(Sys][(Str))$	$((Str)][(Sys))$
$(Str][Sys]$	$((Str)][Sys]$	$(Str][(Sys)]$	$((Sys)][Str]$	$(Sys][(Str)]$	$((Str)][(Sys)]$

[Str)(Sys)	[(Str))(Sys)	[Str)((Sys))	[(Sys))(Str)	[Sys)((Str))	[(Str))((Sys))
[Str)(Sys]	[(Str))(Sys]	[Str)((Sys)]	[(Sys))(Str]	[Sys)((Str)]	[(Str))((Sys)]
[Str][Sys)	[(Str)][Sys)	[Str][((Sys))	[(Sys)][(Str)	[Sys][((Str))	[(Str)][((Sys))
[Str][Sys]	[(Str)][Sys]	[Str][((Sys)]	[(Sys)][(Str]	[Sys][((Str)]	[(Str)][((Sys)]

[Str](Sys)	[(Str)](Sys)	[Str]((Sys))	[(Sys)](Str)	[Sys]((Str))	[(Str)]((Sys))
[Str](Sys]	[(Str)](Sys]	[Str]((Sys)]	[(Sys)](Str]	[Sys]((Str)]	[(Str)]((Sys)]
[Str][Sys)	[(Str)][Sys)	[Str][((Sys))	[(Sys)][(Str)	[Sys][((Str))	[(Str)][((Sys))
[Str][Sys]	[(Str)][Sys]	[Str][((Sys)]	[(Sys)][(Str]	[Sys][((Str)]	[(Str)][((Sys)]

Kenogrammatisches System

(oo)(ooo)	((oo))(ooo)	(oo)((ooo))	((ooo))(oo)	(ooo)((oo))	((oo))((ooo))
(oo)(ooo]	((oo))(ooo]	(oo)((ooo)]	((ooo))(oo]	(ooo)((oo)]	((oo))((ooo)]
(oo)[ooo)	((oo))[ooo)	(oo)[(ooo))	((ooo))[oo)	(ooo)[(oo))	((oo))[((ooo))
(oo)[ooo]	((oo))[ooo]	(oo)[(ooo)]	((ooo))[oo]	(ooo)[(oo)]	((oo))[((ooo)]

(oo)](ooo)	((oo)](ooo)	(oo)]((ooo))	((ooo)](oo)	(ooo)]((oo))	((oo)]((ooo))
(oo)](ooo]	((oo)](ooo]	(oo)]((ooo)]	((ooo)](oo]	(ooo)]((oo)]	(oo)]((ooo)]
(oo)](ooo)	((oo)](ooo)	(oo)]((ooo))	((ooo)](oo)	(ooo)]((oo))	((oo)]((ooo))
(oo)](ooo]	((oo)](ooo]	(oo)]((ooo)]	((ooo)](oo]	(ooo)]((oo)]	((oo)]((ooo)]

[oo)(ooo)	[(oo))(ooo)	[oo)((ooo))	[(ooo))(oo)	[ooo)((oo))	[(oo))((ooo))
[oo)(ooo]	[(oo))(ooo]	[oo)((ooo)]	[(ooo))(oo]	[ooo)((oo)]	[(oo))((ooo)]
[oo][ooo)	[(oo)][ooo)	[oo][((ooo))	[(ooo)][oo)	[ooo][((oo))	[(oo)][((ooo))
[oo][ooo]	[(oo)][ooo]	[oo][((ooo)]	[(ooo)][oo]	[ooo][((oo)]	[(oo)][((ooo)]

[oo](ooo)	[(oo)](ooo)	[oo]((ooo))	[(ooo)](oo)	[ooo]((oo))	[(oo)]((ooo))
[oo](ooo]	[(oo)](ooo]	[oo]((ooo)]	[(ooo)](oo]	[ooo]((oo)]	[(oo)]((ooo)]
[oo][ooo)	[(oo)][ooo)	[oo][((ooo))	[(ooo)][oo)	[ooo][((oo))	[(oo)][((ooo))
[oo][ooo]	[(oo)][ooo]	[oo][((ooo)]	[(ooo)][oo]	[ooo][((oo)]	[(oo)][((ooo)]

Semiotisches System

(1.2)(2.1)	((1.2))(2.1)	(1.2)((2.1))	((2.1))(1.2)	(2.1)((1.2))	((1.2))((2.1))
(1.2)(2.1]	((1.2))(2.1]	(1.2)((2.1)]	((2.1))(1.2]	(2.1)((1.2)]	((1.2))((2.1)]
(1.2)[2.1)	((1.2))[2.1)	(1.2)[(2.1))	((2.1))[1.2)	(2.1)[(1.2))	((1.2))[((2.1))
(1.2)[2.1]	((1.2))[2.1]	(1.2)[(2.1)]	((2.1))[1.2]	(2.1)[(1.2)]	((1.2))[((2.1)]

(1.2](2.1)	((1.2)](2.1)	(1.2]((2.1))	((2.1)](1.2)	(2.1]((1.2))	((1.2)]((2.1))
(1.2](2.1]	((1.2)](2.1]	(1.2]((2.1)]	((2.1)](1.2]	(2.1]((1.2)]	(1.2]((2.1)]
(1.2][2.1)	((1.2)](2.1)	(1.2]((2.1))	((2.1)](1.2)	(2.1]((1.2))	((1.2)]((2.1))
(1.2][2.1]	((1.2)](2.1]	(1.2]((2.1)]	((2.1)](1.2]	(2.1]((1.2)]	((1.2)]((2.1)]

[1.2)(2.1)	[(1.2))(2.1)	[1.2)((2.1))	[(2.1))(1.2)	[2.1)((1.2))	[(1.2))((2.1))
[1.2)(2.1]	[(1.2))(2.1]	[1.2)((2.1)]	[(2.1))(1.2]	[2.1)((1.2)]	[(1.2))((2.1)]
[1.2)[2.1)	[(1.2))[2.1)	[1.2][(2.1))	[(2.1)][1.2)	[2.1][(1.2))	[(1.2))[(2.1))
[1.2)[2.1]	[(1.2))[2.1]	[1.2][(2.1)]	[(2.1)][1.2]	[2.1][(1.2)]	[(1.2))[(2.1)]
[1.2](2.1)	[(1.2)](2.1)	[1.2]((2.1))	[(2.1)](1.2)	[2.1]((1.2))	[(1.2)]((2.1))
[1.2](2.1]	[(1.2)](2.1]	[1.2]((2.1)]	[(2.1)](1.2]	[2.1]((1.2)]	[(1.2)]((2.1)]
[1.2][2.1)	[(1.2)][2.1)	[1.2][(2.1))	[(2.1)][1.2)	[2.1][(1.2))	[(1.2)][(2.1))
[1.2][2.1]	[(1.2)][2.1]	[1.2][(2.1)]	[(2.1)][1.2]	[2.1][(1.2)]	[(1.2)][(2.1)].

R*-System

Ontisches System

(Sys)(Str)	((Sys))(Str)	(Sys)((Str))	((Str))(Sys)	(Str)((Sys))	((Sys))((Str))
(Sys)(Str]	((Sys))(Str]	(Sys)((Str)]	((Str))(Sys]	(Str)((Sys)]	((Sys))((Str)]
(Sys)[Str)	((Sys))[Str)	(Sys)[(Str))	((Str))[Sys)	(Str)[(Sys))	((Sys))[Str))
(Sys)[Str]	((Sys))[Str]	(Sys)[(Str)]	((Str))[Sys]	(Str)[(Sys)]	((Sys))[Str]
(Sys](Str)	((Sys)](Str)	(Sys]((Str))	((Str)](Sys)	(Str]((Sys))	((Sys)]((Str))
(Sys](Str]	((Sys)](Str]	(Sys]((Str)]	((Str)](Sys]	(Str]((Sys)]	(Sys]((Str)]
(Sys][Str)	((Sys)][Str)	(Sys][Str))	((Str)][Sys)	(Str][Str))	((Sys)][Str))
(Sys][Str]	((Sys)][Str]	(Sys][Str)]	((Str)][Sys]	(Str][Str)]	((Sys)][Str]
[Sys)(Str)	[(Sys))(Str)	[Sys)((Str))	[(Str))(Sys)	[Str)((Sys))	[(Sys))((Str))
[Sys)(Str]	[(Sys))(Str]	[Sys)((Str)]	[(Str))(Sys]	[Str)((Sys)]	[(Sys))((Str)]
[Sys)[Str)	[(Sys))[Str)	[Sys][(Str))	[(Str)][Sys)	[Str][(Sys))	[(Sys))[(Str))
[Sys)[Str]	[(Sys))[Str]	[Sys][(Str)]	[(Str)][Sys]	[Str][(Sys)]	[(Sys))[(Str)]
[Sys](Str)	[(Sys)](Str)	[Sys]((Str))	[(Str)](Sys)	[Str]((Sys))	[(Sys)]((Str))
[Sys](Str]	[(Sys)](Str]	[Sys]((Str)]	[(Str)](Sys]	[Str]((Sys)]	[(Sys)]((Str)]
[Sys][Str)	[(Sys)][Str)	[Sys][Str))	[(Str)][Sys)	[Str][Str))	[(Sys)][Str))
[Sys][Str]	[(Sys)][Str]	[Sys][Str)]	[(Str)][Sys]	[Str][Str)]	[(Sys)][Str]

Kenogrammatisches System

(ooo)(oo)	((ooo))(oo)	(ooo)((oo))	((oo))(ooo)	(oo)((ooo))	((ooo))((oo))
(ooo)(oo]	((ooo))(oo]	(ooo)((oo)]	((oo))(ooo]	(oo)((ooo)]	((ooo))((oo)]

(ooo)[oo] ((ooo))[oo] (ooo)[(oo)] ((oo))[ooo] (oo)[(ooo)] ((ooo))[(oo)]
 (ooo)[oo] ((ooo))[oo] (ooo)[(oo)] ((oo))[ooo] (oo)[(ooo)] ((ooo))[(oo)]

(ooo)(oo) ((ooo)](oo) (ooo)((oo)) ((oo)](ooo) (oo]((ooo)) ((ooo)]((oo))
 (ooo)(oo) ((ooo)](oo) (ooo)((oo)] ((oo)](ooo)] (oo]((ooo)] (ooo)]((oo)]
 (ooo)[oo] ((ooo)](oo) (ooo)][(oo)] ((oo)](ooo) (oo)][(ooo)] ((ooo)][(oo)]
 (ooo)[oo] ((ooo)](oo) (ooo)][(oo)] ((oo)](ooo) (oo)][(ooo)] ((ooo)][(oo)]

[ooo)(oo) [(ooo))(oo) [ooo)((oo)) [(oo))(ooo) [oo]((ooo)) [(ooo))((oo))
 [ooo)(oo) [(ooo))(oo) [ooo)((oo)] [(oo))(ooo] [oo]((ooo)] [(ooo))((oo)]
 [ooo)[oo] [(ooo)](oo) [ooo)][(oo)] [(oo)](ooo) [oo)][(ooo)] [(ooo)][(oo)]
 [ooo)[oo] [(ooo)](oo) [ooo)][(oo)] [(oo)](ooo) [oo)][(ooo)] [(ooo)][(oo)]

[ooo](oo) [(ooo)](oo) [ooo]((oo)) [(oo)](ooo) [oo]((ooo)) [(ooo)]((oo))
 [ooo](oo) [(ooo)](oo) [ooo]((oo)] [(oo)](ooo) [oo]((ooo)] [(ooo)]((oo)]
 [ooo][oo] [(ooo)](oo) [ooo)][(oo)] [(oo)](ooo) [oo)][(ooo)] [(ooo)][(oo)]
 [ooo][oo] [(ooo)](oo) [ooo)][(oo)] [(oo)](ooo) [oo)][(ooo)] [(ooo)][(oo)]

Semiotisches System

(2.1)(1.2) ((2.1))(1.2) (2.1)((1.2)) ((1.2))(2.1) (1.2)((2.1)) ((2.1))((1.2))
 (2.1)(1.2] ((2.1))(1.2] (2.1)((1.2)] ((1.2))(2.1] (1.2)((2.1)] ((2.1))((1.2)]
 (2.1)[1.2) ((2.1))[1.2) (2.1)[(1.2)) ((1.2)][2.1) (1.2)[(2.1)) ((2.1)][(1.2))
 (2.1)[1.2] ((2.1))[1.2] (2.1)[(1.2)] ((1.2)][2.1] (1.2)[(2.1)] ((2.1)][(1.2)]

(2.1](1.2) ((2.1)](1.2) (2.1]((1.2)) ((1.2)](2.1) (1.2]((2.1)) ((2.1)]((1.2))
 (2.1](1.2] ((2.1)](1.2] (2.1]((1.2)] ((1.2)](2.1] (1.2]((2.1)] (2.1]((1.2)]
 (2.1][1.2) ((2.1)][1.2) (2.1][[(1.2)) ((1.2)][2.1) (1.2][[(2.1)) ((2.1)][[(1.2))
 (2.1][1.2] ((2.1)][1.2] (2.1][[(1.2)] ((1.2)][2.1] (1.2][[(2.1)] ((2.1)][[(1.2)]

[2.1)(1.2) [(2.1))(1.2) [2.1)((1.2)) [(1.2))(2.1) [1.2)((2.1)) [(2.1))((1.2))
 [2.1)(1.2] [(2.1))(1.2] [2.1)((1.2)] [(1.2))(2.1] [1.2)((2.1)] [(2.1))((1.2)]
 [2.1][1.2) [(2.1)][1.2) [2.1)[(1.2)) [(1.2)][2.1) [1.2)[(2.1)) [(2.1)][(1.2))
 [2.1][1.2] [(2.1)][1.2] [2.1)[(1.2)] [(1.2)][2.1] [1.2)[(2.1)] [(2.1)][(1.2)]

[2.1](1.2) [(2.1)](1.2) [2.1]((1.2)) [(1.2)](2.1) [1.2]((2.1)) [(2.1)]((1.2))
 [2.1](1.2] [(2.1)](1.2] [2.1]((1.2)] [(1.2)](2.1] [1.2]((2.1)] [(2.1)]((1.2)]
 [2.1][1.2) [(2.1)][1.2) [2.1][[(1.2)) [(1.2)][2.1] [1.2][[(2.1)) [(2.1)][[(1.2))
 [2.1][1.2] [(2.1)][1.2] [2.1][[(1.2)] [(1.2)][2.1] [1.2][[(2.1)] [(2.1)][[(1.2)]

2.5. (1.2, 2.2)-System

R*-System

Ontisches System

(Str)(Abb) ((Str))(Abb) (Str)((Abb)) ((Abb))(Str) (Abb)((Str)) ((Str))((Abb))
 (Str)[Abb] ((Str))[Abb] (Str)[(Abb)] ((Abb))[Str] (Abb)[(Str)] ((Str))[(Abb)]
 (Str)[Abb] ((Str))[Abb] (Str)[(Abb)] ((Abb))[Str] (Abb)[(Str)] ((Str))[(Abb)]

(Str](Abb) ((Str)](Abb) (Str]((Abb)) ((Abb)](Str) (Abb]((Str)) ((Str)]((Abb))
 (Str](Abb) ((Str)](Abb) (Str]((Abb)] ((Abb)](Str] (Abb]((Str)] (Str]((Abb)]
 (Str][Abb] ((Str)][Abb] (Str][[Abb]) ((Abb)](Str] (Abb][[Str]) ((Str)][[Abb])
 (Str][Abb] ((Str)][Abb] (Str][[Abb]) ((Abb)](Str] (Abb][[Str]) ((Str)][[Abb])

[Str)(Abb) [(Str))(Abb) [Str)((Abb)) [(Abb))(Str) [Abb)((Str)) [(Str))((Abb))
 [Str)(Abb) [(Str))(Abb) [Str)((Abb)] [(Abb))(Str] [Abb)((Str)] [(Str))((Abb)]
 [Str][Abb] [(Str)][Abb] [Str][[Abb)) [(Abb)](Str] [Abb][[Str]) [(Str)][[Abb))
 [Str][Abb] [(Str)][Abb] [Str][[Abb)] [(Abb)](Str] [Abb][[Str)] [(Str)][[Abb)]

[Str](Abb) [(Str)](Abb) [Str]((Abb)) [(Abb)](Str) [Abb]((Str)) [(Str)]((Abb))
 [Str](Abb) [(Str)](Abb) [Str]((Abb)] [(Abb)](Str] [Abb]((Str)] [(Str)]((Abb)]
 [Str][Abb] [(Str)][Abb] [Str][[Abb)) [(Abb)](Str] [Abb][[Str)) [(Str)][[Abb))
 [Str][Abb] [(Str)][Abb] [Str][[Abb)] [(Abb)](Str] [Abb][[Str)] [(Str)][[Abb)].

Kenogrammisches System

(oo)(ooΔ) ((oo))(ooΔ) (oo)((ooΔ)) ((ooΔ))(oo) (ooΔ)((oo)) ((oo))((ooΔ))
 (oo)(ooΔ) ((oo))(ooΔ) (oo)((ooΔ)] ((ooΔ))(oo) (ooΔ)((oo)] ((oo))((ooΔ)]
 (oo)[ooΔ) ((oo))[ooΔ) (oo)[(ooΔ)) ((ooΔ)](oo) (ooΔ)[(oo)) ((oo))[ooΔ))
 (oo)[ooΔ) ((oo))[ooΔ) (oo)[(ooΔ)] ((ooΔ)](oo) (ooΔ)[(oo)] ((oo))[ooΔ)]

(oo](ooΔ) ((oo)](ooΔ) (oo]((ooΔ)) ((ooΔ)](oo) (ooΔ]((oo)) ((oo)]((ooΔ))
 (oo](ooΔ) ((oo)](ooΔ) (oo]((ooΔ)] ((ooΔ)](oo] (ooΔ]((oo)] (oo]((ooΔ)]
 (oo][ooΔ) ((oo)][ooΔ) (oo][[ooΔ)) ((ooΔ)](oo) (ooΔ][[oo)) ((oo)][[ooΔ))
 (oo][ooΔ) ((oo)][ooΔ) (oo][[ooΔ)] ((ooΔ)](oo) (ooΔ][[oo)] ((oo)][[ooΔ)]

[oo)(ooΔ) [(oo))(ooΔ) [oo)((ooΔ)) [(ooΔ))(oo) [ooΔ)((oo)) [(oo))((ooΔ))
 [oo)(ooΔ) [(oo))(ooΔ) [oo)((ooΔ)] [(ooΔ))(oo) [ooΔ)((oo)] [(oo))((ooΔ)]
 [oo][ooΔ) [(oo)][ooΔ) [oo][[ooΔ)) [(ooΔ)](oo) [ooΔ)[(oo)) [(oo)][[ooΔ))
 [oo][ooΔ) [(oo)][ooΔ) [oo][[ooΔ)] [(ooΔ)](oo) [ooΔ)[(oo)] [(oo)][[ooΔ)]

[oo](ooΔ) [(oo)](ooΔ) [oo]((ooΔ)) [(ooΔ)](oo) [ooΔ]((oo)) [(oo)]((ooΔ))
 [oo](ooΔ) [(oo)](ooΔ) [oo]((ooΔ)] [(ooΔ)](oo] [ooΔ]((oo)] [(oo)]((ooΔ)]
 [oo][ooΔ) [(oo)][ooΔ) [oo][[ooΔ)) [(ooΔ)](oo) [ooΔ][[oo)) [(oo)][[ooΔ))
 [oo][ooΔ) [(oo)][ooΔ) [oo][[ooΔ)] [(ooΔ)](oo) [ooΔ][[oo)] [(oo)][[ooΔ)].

Semiotisches System

(1.2)(2.2)	((1.2))(2.2)	(1.2)((2.2))	((2.2))(1.2)	(2.2)((1.2))	((1.2))((2.2))
(1.2)(2.2]	((1.2))(2.2]	(1.2)((2.2])	((2.2))(1.2]	(2.2)((1.2])	((1.2))((2.2])
(1.2)[2.2)	((1.2))[2.2)	(1.2)[(2.2))	((2.2))[1.2)	(2.2)[(1.2))	((1.2))[2.2))
(1.2)[2.2]	((1.2))[2.2]	(1.2)[(2.2)]	((2.2))[1.2]	(2.2)[(1.2)]	((1.2))[2.2]

(1.2](2.2)	((1.2)](2.2)	(1.2]((2.2))	((2.2)](1.2)	(2.2]((1.2))	((1.2)]((2.2))
(1.2](2.2]	((1.2)](2.2]	(1.2]((2.2])	((2.2)](1.2]	(2.2]((1.2])	(1.2]((2.2])
(1.2][2.2)	((1.2)][2.2)	(1.2][2.2))	((2.2)][1.2)	(2.2][2.2))	((1.2)][2.2))
(1.2][2.2]	((1.2)][2.2]	(1.2][2.2)]	((2.2)][1.2]	(2.2][2.2)]	((1.2)][2.2]

[1.2)(2.2)	[(1.2))(2.2)	[1.2)((2.2))	[(2.2))(1.2)	[2.2)((1.2))	[(1.2))((2.2))
[1.2)(2.2]	[(1.2))(2.2]	[1.2)((2.2])	[(2.2))(1.2]	[2.2)((1.2])	[(1.2))((2.2])
[1.2)[2.2)	[(1.2))[2.2)	[1.2)[(2.2))	[(2.2))[1.2)	[2.2)[(1.2))	[(1.2))[2.2))
[1.2)[2.2]	[(1.2))[2.2]	[1.2)[(2.2)]	[(2.2))[1.2]	[2.2)[(1.2)]	[(1.2))[2.2]

[1.2](2.2)	[(1.2)](2.2)	[1.2]((2.2))	[(2.2)](1.2)	[2.2]((1.2))	[(1.2)]((2.2))
[1.2](2.2]	[(1.2)](2.2]	[1.2]((2.2])	[(2.2)](1.2]	[2.2]((1.2])	[(1.2)]((2.2])
[1.2][2.2)	[(1.2)][2.2)	[1.2][2.2))	[(2.2)][1.2)	[2.2][2.2))	[(1.2)][2.2))
[1.2][2.2]	[(1.2)][2.2]	[1.2][2.2)]	[(2.2)][1.2]	[2.2][2.2)]	[(1.2)][2.2]

R*-System

Ontisches System

(Abb)(Str)	((Abb))(Str)	(Abb)((Str))	((Str))(Abb)	(Str)((Abb))	((Abb))((Str))
(Abb)(Str]	((Abb))(Str]	(Abb)((Str])	((Str))(Abb]	(Str)((Abb])	((Abb))((Str])
(Abb)[Str)	((Abb))[Str)	(Abb)[(Str))	((Str))[Abb)	(Str)[(Abb))	((Abb))[2.2))
(Abb)[Str]	((Abb))[Str]	(Abb)[(Str)]	((Str))[Abb]	(Str)[(Abb)]	((Abb))[2.2]

(Abb](Str)	((Abb)](Str)	(Abb]((Str))	((Str)](Abb)	(Str]((Abb))	((Abb)]((Str))
(Abb](Str]	((Abb)](Str]	(Abb]((Str])	((Str)](Abb]	(Str]((Abb])	(Abb]((Str])
(Abb][Str)	((Abb)][Str)	(Abb][2.2))	((Str)][Abb)	(Str][2.2))	((Abb)][2.2))
(Abb][Str]	((Abb)][Str]	(Abb][2.2)]	((Str)][Abb]	(Str][2.2)]	((Abb)][2.2]

[Abb)(Str)	[(Abb))(Str)	[Abb)((Str))	[(Str))(Abb)	[Str)((Abb))	[(Abb))((Str))
[Abb)(Str]	[(Abb))(Str]	[Abb)((Str])	[(Str))(Abb]	[Str)((Abb])	[(Abb))((Str])
[Abb)[Str)	[(Abb))[Str)	[Abb)[(Str))	[(Str))[Abb)	[Str)[(Abb))	[(Abb))[2.2))
[Abb)[Str]	[(Abb))[Str]	[Abb)[(Str)]	[(Str))[Abb]	[Str)[(Abb)]	[(Abb))[2.2]

[Abb](Str)	[(Abb)](Str)	[Abb]((Str))	[(Str)](Abb)	[Str]((Abb))	[(Abb)]((Str))
------------	--------------	--------------	--------------	--------------	----------------

[Abb](Str)	[(Abb)](Str)	[Abb]((Str))	[(Str)](Abb)	[Str]((Abb))	[(Abb)]((Str))
[Abb][Str]	[(Abb)][Str]	[Abb][((Str))]	[(Str)][Abb]	[Str][((Abb))]	[(Abb)][((Str))]
[Abb][Str]	[(Abb)][Str]	[Abb][((Str))]	[(Str)][Abb]	[Str][((Abb))]	[(Abb)][((Str))]

Kenogrammatisches System

(ooΔ)(oo)	((ooΔ))(oo)	(ooΔ)((oo))	((oo))(ooΔ)	(oo)((ooΔ))	((ooΔ))((oo))
(ooΔ)(oo]	((ooΔ))(oo]	(ooΔ)((oo)]	((oo))(ooΔ]	(oo)((ooΔ)]	((ooΔ))((oo)]
(ooΔ)[oo)	((ooΔ))[oo)	(ooΔ)[(oo))	((oo))[ooΔ)	(oo)[(ooΔ))	((ooΔ))[((oo))
(ooΔ)[oo]	((ooΔ))[oo]	(ooΔ)[(oo)]	((oo))[ooΔ]	(oo)[(ooΔ)]	((ooΔ))[((oo)]

(ooΔ](oo)	((ooΔ)](oo)	(ooΔ]((oo))	((oo)](ooΔ)	(oo]((ooΔ))	((ooΔ)]((oo))
(ooΔ](oo]	((ooΔ)](oo]	(ooΔ]((oo)]	((oo)](ooΔ]	(oo]((ooΔ)]	((ooΔ)]((oo)]
(ooΔ][oo)	((ooΔ)][oo)	(ooΔ][(oo))	((oo)][ooΔ)	(oo][((ooΔ))	((ooΔ)][((oo))
(ooΔ][oo]	((ooΔ)][oo]	(ooΔ][(oo)]	((oo)][ooΔ]	(oo][((ooΔ)]	((ooΔ)][((oo)]

[ooΔ)(oo)	[(ooΔ))(oo)	[ooΔ)((oo))	[(oo))(ooΔ)	[oo]((ooΔ))	[(ooΔ))((oo))
[ooΔ)(oo]	[(ooΔ))(oo]	[ooΔ)((oo)]	[(oo))(ooΔ]	[oo]((ooΔ)]	[(ooΔ))((oo)]
[ooΔ][oo)	[(ooΔ)][oo)	[ooΔ][(oo))	[(oo)][ooΔ)	[oo][((ooΔ))	[(ooΔ)][((oo))
[ooΔ][oo]	[(ooΔ)][oo]	[ooΔ][(oo)]	[(oo)][ooΔ]	[oo][((ooΔ)]	[(ooΔ)][((oo)]

[ooΔ](oo)	[(ooΔ)](oo)	[ooΔ]((oo))	[(oo)](ooΔ)	[oo]((ooΔ))	[(ooΔ)]((oo))
[ooΔ](oo]	[(ooΔ)](oo]	[ooΔ]((oo)]	[(oo)](ooΔ]	[oo]((ooΔ)]	[(ooΔ)]((oo)]
[ooΔ][oo)	[(ooΔ)][oo)	[ooΔ][(oo))	[(oo)][ooΔ)	[oo][((ooΔ))	[(ooΔ)][((oo))
[ooΔ][oo]	[(ooΔ)][oo]	[ooΔ][(oo)]	[(oo)][ooΔ]	[oo][((ooΔ)]	[(ooΔ)][((oo)]

Semiotisches System

(2.2)(1.2)	((2.2))(1.2)	(2.2)((1.2))	((1.2))(2.2)	(1.2)((2.2))	((2.2))((1.2))
(2.2)(1.2]	((2.2))(1.2]	(2.2)((1.2)]	((1.2))(2.2]	(1.2)((2.2)]	((2.2))((1.2)]
(2.2)[1.2)	((2.2))[1.2)	(2.2)[(1.2))	((1.2))[2.2)	(1.2)[(2.2))	((2.2))[((1.2))
(2.2)[1.2]	((2.2))[1.2]	(2.2)[(1.2)]	((1.2))[2.2]	(1.2)[(2.2)]	((2.2))[((1.2)]

(2.2](1.2)	((2.2)](1.2)	(2.2]((1.2))	((1.2)](2.2)	(1.2]((2.2))	((2.2)]((1.2))
(2.2](1.2]	((2.2)](1.2]	(2.2]((1.2)]	((1.2)](2.2]	(1.2]((2.2)]	(2.2]((1.2)]
(2.2][1.2)	((2.2)][1.2)	(2.2][((1.2))	((1.2)][2.2)	(1.2][((2.2))	((2.2)][((1.2))
(2.2][1.2]	((2.2)][1.2]	(2.2][((1.2)]	((1.2)][2.2]	(1.2][((2.2)]	((2.2)][((1.2)]

[2.2)(1.2)	[(2.2))(1.2)	[2.2)((1.2))	[(1.2))(2.2)	[1.2]((2.2))	[(2.2))((1.2))
[2.2)(1.2]	[(2.2))(1.2]	[2.2)((1.2)]	[(1.2))(2.2]	[1.2]((2.2)]	[(2.2))((1.2)]
[2.2][1.2)	[(2.2)][1.2)	[2.2][(1.2))	[(1.2)][2.2)	[1.2][((2.2))	[(2.2)][((1.2))
[2.2][1.2]	[(2.2)][1.2]	[2.2][(1.2)]	[(1.2)][2.2]	[1.2][((2.2)]	[(2.2)][((1.2)]

[2.2](1.2)	[(2.2)](1.2)	[2.2]((1.2))	[(1.2)](2.2)	[1.2]((2.2))	[(2.2)]((1.2))
[2.2](1.2)	[(2.2)](1.2)	[2.2]((1.2))	[(1.2)](2.2)	[1.2]((2.2))	[(2.2)]((1.2))
[2.2][1.2]	[(2.2)][1.2]	[2.2][(1.2)]	[(1.2)][2.2]	[1.2][(2.2)]	[(2.2)][(1.2)]
[2.2][1.2]	[(2.2)][1.2]	[2.2][(1.2)]	[(1.2)][2.2]	[1.2][(2.2)]	[(2.2)][(1.2)]

2.6. (1.2, 2.3)-System

R-System

Ontisches System

(Str)(Rep)	((Str))(Rep)	(Str)((Rep))	((Rep))(Str)	(Rep)((Str))	((Str))((Rep))
(Str)[Rep]	((Str))[Rep]	(Str)[(Rep)]	((Rep))[Str]	(Rep)[(Str)]	((Str))[Rep]
(Str)(Rep)	((Str))(Rep)	(Str)((Rep))	((Rep))(Str)	(Rep)((Str))	((Str))((Rep))
(Str)[Rep]	((Str))[Rep]	(Str)[(Rep)]	((Rep))[Str]	(Rep)[(Str)]	((Str))[Rep]

(Str](Rep)	((Str)](Rep)	(Str]((Rep))	((Rep)](Str)	(Rep]((Str))	((Str]](Rep))
(Str](Rep]	((Str)](Rep]	(Str]((Rep])	((Rep)](Str]	(Rep]((Str])	(Str]((Rep])
(Str][Rep)	((Str)][Rep)	(Str][Rep))	((Rep)][Str)	(Rep][Str))	((Str)][Rep))
(Str][Rep]	((Str)][Rep]	(Str][Rep])	((Rep)][Str]	(Rep][Str])	((Str)][Rep])

[Str)(Rep)	[(Str))(Rep)	[Str)((Rep))	[(Rep))(Str)	[Rep)((Str))	[(Str))((Rep))
[Str)(Rep]	[(Str))(Rep]	[Str)((Rep])	[(Rep))(Str]	[Rep)((Str])	[(Str))((Rep])
[Str][Rep)	[(Str)][Rep)	[Str][Rep))	[(Rep)][Str)	[Rep][Str))	[(Str)][Rep))
[Str][Rep]	[(Str)][Rep]	[Str][Rep])	[(Rep)][Str]	[Rep][Str])	[(Str)][Rep])

[Str](Rep)	[(Str)](Rep)	[Str]((Rep))	[(Rep)](Str)	[Rep]((Str))	[(Str]](Rep))
[Str](Rep]	[(Str)](Rep]	[Str]((Rep])	[(Rep)](Str]	[Rep]((Str])	[(Str]](Rep])
[Str][Rep)	[(Str)][Rep)	[Str][Rep))	[(Rep)][Str)	[Rep][Str))	[(Str)][Rep))
[Str][Rep]	[(Str)][Rep]	[Str][Rep])	[(Rep)][Str]	[Rep][Str])	[(Str)][Rep])

Kenogrammatisches System

(oo)(oΔ□)	((oo))(oΔ□)	(oo)((oΔ□))	((oΔ□))(oo)	(oΔ□)((oo))	((oo))((oΔ□))
(oo)(oΔ□]	((oo))(oΔ□]	(oo)((oΔ□])	((oΔ□])(oo)	(oΔ□)((oo))	((oo))((oΔ□])
(oo)[oΔ□)	((oo))[oΔ□)	(oo)[(oΔ□))	((oΔ□)][oo)	(oΔ□)[(oo))	((oo))[oΔ□))
(oo)[oΔ□]	((oo))[oΔ□]	(oo)[(oΔ□)]	((oΔ□)][oo]	(oΔ□)[(oo)]	((oo))[oΔ□]

(oo](oΔ□)	((oo)](oΔ□)	(oo]((oΔ□))	((oΔ□)](oo)	(oΔ□]((oo))	((oo]](oΔ□))
(oo](oΔ□]	((oo)](oΔ□]	(oo]((oΔ□])	((oΔ□)](oo]	(oΔ□]((oo))	(oo]((oΔ□])
(oo][oΔ□)	((oo)][oΔ□)	(oo][oΔ□))	((oΔ□)][oo)	(oΔ□][oo))	((oo)][oΔ□))
(oo][oΔ□]	((oo)][oΔ□]	(oo][oΔ□])	((oΔ□)][oo]	(oΔ□][oo])	((oo)][oΔ□])

$[\circ\circ)(\circ\Delta\Box]$ $[(\circ\circ))(\circ\Delta\Box]$ $[\circ\circ)((\circ\Delta\Box))$ $[(\circ\Delta\Box))(\circ\circ)$ $[\circ\Delta\Box)((\circ\circ))$ $[(\circ\circ))((\circ\Delta\Box))$
 $[\circ\circ)(\circ\Delta\Box]$ $[(\circ\circ))(\circ\Delta\Box]$ $[\circ\circ)((\circ\Delta\Box))$ $[(\circ\Delta\Box))(\circ\circ)$ $[\circ\Delta\Box)((\circ\circ))$ $[(\circ\circ))((\circ\Delta\Box))$
 $[\circ\circ)[\circ\Delta\Box]$ $[(\circ\circ))[\circ\Delta\Box]$ $[\circ\circ][(\circ\Delta\Box)]$ $[(\circ\Delta\Box))[\circ\circ]$ $[\circ\Delta\Box][(\circ\circ))$ $[(\circ\circ))[(\circ\Delta\Box)]$
 $[\circ\circ)[\circ\Delta\Box]$ $[(\circ\circ))[\circ\Delta\Box]$ $[\circ\circ][(\circ\Delta\Box)]$ $[(\circ\Delta\Box))[\circ\circ]$ $[\circ\Delta\Box][(\circ\circ))$ $[(\circ\circ))[(\circ\Delta\Box)]$

$[\circ\circ](\circ\Delta\Box)$ $[(\circ\circ)](\circ\Delta\Box)$ $[\circ\circ)((\circ\Delta\Box))$ $[(\circ\Delta\Box)](\circ\circ)$ $[\circ\Delta\Box)((\circ\circ))$ $[(\circ\circ))((\circ\Delta\Box))$
 $[\circ\circ](\circ\Delta\Box)$ $[(\circ\circ)](\circ\Delta\Box)$ $[\circ\circ)((\circ\Delta\Box))$ $[(\circ\Delta\Box)](\circ\circ)$ $[\circ\Delta\Box)((\circ\circ))$ $[(\circ\circ))((\circ\Delta\Box))$
 $[\circ\circ][\circ\Delta\Box]$ $[(\circ\circ)][\circ\Delta\Box]$ $[\circ\circ][(\circ\Delta\Box)]$ $[(\circ\Delta\Box)][\circ\circ]$ $[\circ\Delta\Box][(\circ\circ))$ $[(\circ\circ))[(\circ\Delta\Box)]$
 $[\circ\circ][\circ\Delta\Box]$ $[(\circ\circ)][\circ\Delta\Box]$ $[\circ\circ][(\circ\Delta\Box)]$ $[(\circ\Delta\Box)][\circ\circ]$ $[\circ\Delta\Box][(\circ\circ))$ $[(\circ\circ))[(\circ\Delta\Box)]$.

Semiotisches System

$(1.2)(2.3)$ $((1.2))(2.3)$ $(1.2)((2.3))$ $((2.3))(1.2)$ $(2.3)((1.2))$ $((1.2))((2.3))$
 $(1.2)(2.3]$ $((1.2))(2.3]$ $(1.2)((2.3])$ $((2.3))(1.2]$ $(2.3)((1.2])$ $((1.2))((2.3])$
 $(1.2)[2.3)$ $((1.2))[2.3)$ $(1.2)[(2.3))$ $((2.3))[1.2)$ $(2.3)[(1.2))$ $((1.2))[2.3))$
 $(1.2)[2.3]$ $((1.2))[2.3]$ $(1.2)[(2.3)]$ $((2.3))[1.2]$ $(2.3)[(1.2)]$ $((1.2))[2.3]$

$(1.2](2.3)$ $((1.2)](2.3)$ $(1.2]((2.3))$ $((2.3)](1.2)$ $(2.3]((1.2))$ $((1.2)]((2.3))$
 $(1.2](2.3]$ $((1.2)](2.3]$ $(1.2]((2.3])$ $((2.3)](1.2]$ $(2.3]((1.2])$ $((1.2)]((2.3])$
 $(1.2][2.3)$ $((1.2)][2.3)$ $(1.2][(2.3))$ $((2.3)][1.2)$ $(2.3][(1.2))$ $((1.2)][2.3))$
 $(1.2][2.3]$ $((1.2)][2.3]$ $(1.2][(2.3)]$ $((2.3)][1.2]$ $(2.3][(1.2)]$ $((1.2)][2.3]$

$[1.2)(2.3)$ $[(1.2))(2.3)$ $[1.2)((2.3))$ $[(2.3))(1.2)$ $[2.3)((1.2))$ $[(1.2))((2.3))$
 $[1.2)(2.3]$ $[(1.2))(2.3]$ $[1.2)((2.3])$ $[(2.3))(1.2]$ $[2.3)((1.2])$ $[(1.2))((2.3])$
 $[1.2)[2.3)$ $[(1.2))[2.3)$ $[1.2)[(2.3))$ $[(2.3))[1.2)$ $[2.3)[(1.2))$ $[(1.2))[2.3))$
 $[1.2)[2.3]$ $[(1.2))[2.3]$ $[1.2)[(2.3)]$ $[(2.3))[1.2]$ $[2.3)[(1.2)]$ $[(1.2))[2.3]$

$[1.2](2.3)$ $[(1.2)](2.3)$ $[1.2]((2.3))$ $[(2.3)](1.2)$ $[2.3]((1.2))$ $[(1.2)]((2.3))$
 $[1.2](2.3]$ $[(1.2)](2.3]$ $[1.2]((2.3])$ $[(2.3)](1.2]$ $[2.3]((1.2])$ $[(1.2)]((2.3])$
 $[1.2][2.3)$ $[(1.2)][2.3)$ $[1.2][(2.3))$ $[(2.3)][1.2)$ $[2.3][(1.2))$ $[(1.2)][2.3))$
 $[1.2][2.3]$ $[(1.2)][2.3]$ $[1.2][(2.3)]$ $[(2.3)][1.2]$ $[2.3][(1.2)]$ $[(1.2)][2.3]$.

R*-System

Ontisches System

$(Rep)(Str)$ $((Rep))(Str)$ $(Rep)((Str))$ $((Str))(Rep)$ $(Str)((Rep))$ $((Rep))((Str))$
 $(Rep)(Str]$ $((Rep))(Str]$ $(Rep)((Str])$ $((Str))(Rep]$ $(Str)((Rep])$ $((Rep))((Str])$
 $(Rep)[Str)$ $((Rep))[Str)$ $(Rep)[(Str))$ $((Str))[Rep)$ $(Str)[(Rep))$ $((Rep))[Str))$
 $(Rep)[Str]$ $((Rep))[Str]$ $(Rep)[(Str)]$ $((Str))[Rep]$ $(Str)[(Rep)]$ $((Rep))[Str]$
 $(Rep](Str)$ $((Rep)](Str)$ $(Rep]((Str))$ $((Str)](Rep)$ $(Str]((Rep))$ $((Rep)]((Str))$
 $(Rep](Str]$ $((Rep)](Str]$ $(Rep]((Str])$ $((Str)](Rep]$ $(Str]((Rep])$ $(Rep]((Str])$
 $(Rep][Str)$ $((Rep)][Str)$ $(Rep][Str))$ $((Str]][Rep)$ $(Str][Rep))$ $((Rep]][Str))$

(Rep][Str] ((Rep)][Str] (Rep)][(Str)] ((Str)][Rep] (Str)][(Rep)] ((Rep)][(Str)]

[Rep)(Str] [(Rep))(Str] [Rep)((Str)] [(Str))(Rep] [Str)((Rep)] [(Rep))((Str))

[Rep)(Str] [(Rep))(Str] [Rep)((Str)] [(Str))(Rep] [Str)((Rep)] [(Rep))((Str)]

[Rep][Str] [(Rep)][Str] [Rep)][(Str)] [(Str)][Rep] [Str][(Rep)] [(Rep)][(Str)]

[Rep][Str] [(Rep)][Str] [Rep)][(Str)] [(Str)][Rep] [Str][(Rep)] [(Rep)][(Str)]

Kenogrammatisches System

($\circ\Delta\Box$)($\circ\circ$) (($\circ\Delta\Box$))($\circ\circ$) ($\circ\Delta\Box$)(($\circ\circ$)) (($\circ\circ$))($\circ\Delta\Box$) ($\circ\circ$)(($\circ\Delta\Box$)) (($\circ\Delta\Box$))(($\circ\circ$))

($\circ\Delta\Box$)($\circ\circ$] (($\circ\Delta\Box$))($\circ\circ$] ($\circ\Delta\Box$)(($\circ\circ$]) (($\circ\circ$))($\circ\Delta\Box$] ($\circ\circ$)(($\circ\Delta\Box$]) (($\circ\Delta\Box$))(($\circ\circ$])

($\circ\Delta\Box$)[$\circ\circ$] (($\circ\Delta\Box$))[$\circ\circ$] ($\circ\Delta\Box$)[($\circ\circ$)] (($\circ\circ$))[$\circ\Delta\Box$] ($\circ\circ$)[($\circ\Delta\Box$)] (($\circ\Delta\Box$))[($\circ\circ$)]

($\circ\Delta\Box$)[$\circ\circ$] (($\circ\Delta\Box$))[$\circ\circ$] ($\circ\Delta\Box$)[($\circ\circ$)] (($\circ\circ$))[$\circ\Delta\Box$] ($\circ\circ$)[($\circ\Delta\Box$)] (($\circ\Delta\Box$))[($\circ\circ$)]

($\circ\Delta\Box$)($\circ\circ$) (($\circ\Delta\Box$))($\circ\circ$) ($\circ\Delta\Box$)(($\circ\circ$)) (($\circ\circ$))($\circ\Delta\Box$) ($\circ\circ$)(($\circ\Delta\Box$)) (($\circ\Delta\Box$))(($\circ\circ$))

($\circ\Delta\Box$)($\circ\circ$] (($\circ\Delta\Box$))($\circ\circ$] ($\circ\Delta\Box$)(($\circ\circ$]) (($\circ\circ$))($\circ\Delta\Box$] ($\circ\circ$)(($\circ\Delta\Box$]) ($\circ\Delta\Box$))(($\circ\circ$])

($\circ\Delta\Box$)[$\circ\circ$] (($\circ\Delta\Box$))[$\circ\circ$] ($\circ\Delta\Box$)[($\circ\circ$)] (($\circ\circ$))[$\circ\Delta\Box$] ($\circ\circ$)[($\circ\Delta\Box$)] (($\circ\Delta\Box$))[($\circ\circ$)]

($\circ\Delta\Box$)[$\circ\circ$] (($\circ\Delta\Box$))[$\circ\circ$] ($\circ\Delta\Box$)[($\circ\circ$)] (($\circ\circ$))[$\circ\Delta\Box$] ($\circ\circ$)[($\circ\Delta\Box$)] (($\circ\Delta\Box$))[($\circ\circ$)]

[$\circ\Delta\Box$)($\circ\circ$) [($\circ\Delta\Box$))($\circ\circ$] [$\circ\Delta\Box$)(($\circ\circ$)) [($\circ\circ$))($\circ\Delta\Box$] [$\circ\circ$)(($\circ\Delta\Box$)] [($\circ\Delta\Box$))(($\circ\circ$))

[$\circ\Delta\Box$)($\circ\circ$] [($\circ\Delta\Box$))($\circ\circ$] [$\circ\Delta\Box$)(($\circ\circ$]) [($\circ\circ$))($\circ\Delta\Box$] [$\circ\circ$)(($\circ\Delta\Box$)] [($\circ\Delta\Box$))(($\circ\circ$)]

[$\circ\Delta\Box$)[$\circ\circ$] [($\circ\Delta\Box$))[$\circ\circ$] [$\circ\Delta\Box$][($\circ\circ$)] [($\circ\circ$))[$\circ\Delta\Box$] [$\circ\circ$][($\circ\Delta\Box$)] [($\circ\Delta\Box$))[($\circ\circ$)]

[$\circ\Delta\Box$)[$\circ\circ$] [($\circ\Delta\Box$))[$\circ\circ$] [$\circ\Delta\Box$][($\circ\circ$)] [($\circ\circ$))[$\circ\Delta\Box$] [$\circ\circ$][($\circ\Delta\Box$)] [($\circ\Delta\Box$))[($\circ\circ$)]

[$\circ\Delta\Box$]($\circ\circ$) [($\circ\Delta\Box$)]($\circ\circ$) [$\circ\Delta\Box$]($\circ\circ$)) [($\circ\circ$)]($\circ\Delta\Box$] [$\circ\circ$]($\circ\Delta\Box$)) [($\circ\Delta\Box$)]($\circ\circ$))

[$\circ\Delta\Box$]($\circ\circ$] [($\circ\Delta\Box$)]($\circ\circ$] [$\circ\Delta\Box$]($\circ\circ$]) [($\circ\circ$)]($\circ\Delta\Box$] [$\circ\circ$]($\circ\Delta\Box$]) [($\circ\Delta\Box$)]($\circ\circ$])

[$\circ\Delta\Box$][$\circ\circ$] [($\circ\Delta\Box$)]($\circ\circ$) [$\circ\Delta\Box$][($\circ\circ$)] [($\circ\circ$)]($\circ\Delta\Box$] [$\circ\circ$]($\circ\Delta\Box$)] [($\circ\Delta\Box$)]($\circ\circ$)]

[$\circ\Delta\Box$][$\circ\circ$] [($\circ\Delta\Box$)]($\circ\circ$) [$\circ\Delta\Box$][($\circ\circ$)] [($\circ\circ$)]($\circ\Delta\Box$] [$\circ\circ$]($\circ\Delta\Box$)] [($\circ\Delta\Box$)]($\circ\circ$)]

Semiotisches System

(2.3)(1.2) ((2.3))(1.2) (2.3)((1.2)) ((1.2))(2.3) (1.2)((2.3)) ((2.3))((1.2))

(2.3)(1.2] ((2.3))(1.2] (2.3)((1.2]) ((1.2))(2.3] (1.2)((2.3]) ((2.3))((1.2])

(2.3)[1.2] ((2.3))[1.2] (2.3)[(1.2)] ((1.2)][2.3] (1.2)[(2.3)] ((2.3))[1.2]

(2.3)[1.2] ((2.3))[1.2] (2.3)[(1.2)] ((1.2)][2.3] (1.2)[(2.3)] ((2.3))[1.2]

(2.3](1.2) ((2.3)](1.2) (2.3]((1.2)) ((1.2)](2.3) (1.2]((2.3)) ((2.3)]((1.2))

(2.3](1.2] ((2.3)](1.2] (2.3]((1.2]) ((1.2)](2.3] (1.2]((2.3]) (2.3]((1.2])

(2.3][1.2] ((2.3)][1.2] (2.3][1.2]) ((1.2)][2.3] (1.2][2.3]) ((2.3)][1.2])

(2.3][1.2] ((2.3)][1.2] (2.3][1.2]) ((1.2)][2.3] (1.2][2.3]) ((2.3)][1.2])

[2.3](1.2) [(2.3)](1.2) [2.3]((1.2)) [(1.2)](2.3) [1.2]((2.3)) [(2.3)]((1.2))

[2.3](1.2] [(2.3)](1.2] [2.3]((1.2]) [(1.2)](2.3] [1.2]((2.3]) [(2.3)]((1.2])

[2.3][1.2] [(2.3)](1.2) [2.3][1.2]) [(1.2)][2.3] [1.2][2.3]) [(2.3)][1.2]

[2.3][1.2] [(2.3))[1.2] [2.3][(1.2)] [(1.2))[2.3] [1.2][(2.3)] [(2.3))[(1.2)]

2.7. (1.3, 2.1)-System

R-System

Ontisches System

(Obj)(Sys) ((Obj))(Sys) (Obj)((Sys)) ((Sys))(Obj) (Sys)((Obj)) ((Obj))((Sys))
 (Obj)(Sys] ((Obj))(Sys] (Obj)((Sys]) ((Sys))(Obj] (Sys)((Obj]) ((Obj))((Sys])
 (Obj)[Sys) ((Obj))[Sys) (Obj)[(Sys)) ((Sys))[Obj] (Sys)[(Obj)) ((Obj))[Sys)
 (Obj)[Sys] ((Obj))[Sys] (Obj)[(Sys)] ((Sys))[Obj] (Sys)[(Obj)] ((Obj))[Sys]

(Obj](Sys) ((Obj)](Sys) (Obj]((Sys)) ((Sys)](Obj) (Sys]((Obj)) ((Obj)]((Sys))
 (Obj](Sys] ((Obj)](Sys] (Obj]((Sys]) ((Sys)](Obj] (Sys]((Obj]) (Obj]((Sys])
 (Obj])[Sys) ((Obj])[Sys) (Obj] [(Sys)) ((Sys)] [Obj] (Sys] [(Obj)) ((Obj)] [(Sys))
 (Obj])[Sys] ((Obj)] [Sys] (Obj] [(Sys)] ((Sys)] [Obj] (Sys] [(Obj)] ((Obj)] [(Sys)]

[Obj)(Sys) [(Obj))(Sys) [Obj)((Sys)) [(Sys))(Obj] [Sys)((Obj)) [(Obj))((Sys))
 [Obj)(Sys] [(Obj))(Sys] [Obj)((Sys)] [(Sys))(Obj] [Sys)((Obj)] [(Obj))((Sys)]
 [Obj)[Sys) [(Obj))[Sys) [Obj] [(Sys)) [(Sys)] [Obj] [Sys] [(Obj)) [(Obj)] [(Sys))
 [Obj)[Sys] [(Obj))[Sys] [Obj] [(Sys)] [(Sys)] [Obj] [Sys] [(Obj)] [(Obj)] [(Sys)]

[Obj](Sys) [(Obj)](Sys) [Obj]((Sys)) [(Sys)](Obj) [Sys]((Obj)) [(Obj)]((Sys))
 [Obj](Sys] [(Obj)](Sys] [Obj]((Sys]) [(Sys)](Obj] [Sys]((Obj]) [(Obj)]((Sys])
 [Obj])[Sys) [(Obj)] [Sys) [Obj] [(Sys)) [(Sys)] [Obj] [Sys] [(Obj)) [(Obj)] [(Sys))
 [Obj])[Sys] [(Obj)] [Sys] [Obj] [(Sys)] [(Sys)] [Obj] [Sys] [(Obj)] [(Obj)] [(Sys)]

Kenogrammatisches System

(oΔ)(ooo) ((oΔ))(ooo) (oΔ)((ooo)) ((ooo))(oΔ) (ooo)((oΔ)) ((oΔ))((ooo))
 (oΔ)(ooo] ((oΔ))(ooo] (oΔ)((ooo)] ((ooo))(oΔ] (ooo)((oΔ]) ((oΔ))((ooo])
 (oΔ)[ooo) ((oΔ))[ooo) (oΔ)[(ooo)) ((ooo))[oΔ] (ooo)[(oΔ)) ((oΔ))[ooo)
 (oΔ)[ooo] ((oΔ))[ooo] (oΔ)[(ooo)] ((ooo))[oΔ] (ooo)[(oΔ)] ((oΔ))[ooo]

(oΔ](ooo) ((oΔ)](ooo) (oΔ]((ooo)) ((ooo)](oΔ) (ooo]((oΔ)) ((oΔ)]((ooo))
 (oΔ](ooo] ((oΔ)](ooo] (oΔ]((ooo)] ((ooo)](oΔ] (ooo]((oΔ]) (oΔ]((ooo])
 (oΔ])[ooo) ((oΔ)] [ooo) (oΔ] [(ooo)) ((ooo)] [oΔ] (ooo] [(oΔ)) ((oΔ)] [(ooo))
 (oΔ])[ooo] ((oΔ)] [ooo] (oΔ] [(ooo)] ((ooo)] [oΔ] (ooo] [(oΔ)] ((oΔ)] [(ooo)]

[oΔ)(ooo) [(oΔ))(ooo) [oΔ)((ooo)) [(ooo))(oΔ] [ooo)((oΔ)) [(oΔ))((ooo))
 [oΔ)(ooo] [(oΔ))(ooo] [oΔ)((ooo)] [(ooo))(oΔ] [ooo)((oΔ)] [(oΔ))((ooo)]
 [oΔ)[ooo) [(oΔ))[ooo] [oΔ] [(ooo)) [(ooo)] [oΔ] [ooo] [(oΔ)) [(oΔ)] [(ooo))

$[\circ\Delta][\circ\circ\circ]$ $[(\circ\Delta)][\circ\circ\circ]$ $[\circ\Delta][(\circ\circ\circ)]$ $[(\circ\circ\circ)][\circ\Delta]$ $[\circ\circ\circ][(\circ\Delta)]$ $[(\circ\Delta)][(\circ\circ\circ)]$

$[\circ\Delta](\circ\circ\circ)$ $[(\circ\Delta)](\circ\circ\circ)$ $[\circ\Delta](\circ\circ\circ)$ $[(\circ\circ\circ)](\circ\Delta)$ $[\circ\circ\circ](\circ\Delta)$ $[(\circ\Delta)](\circ\circ\circ)$
 $[\circ\Delta](\circ\circ\circ)$ $[(\circ\Delta)](\circ\circ\circ)$ $[\circ\Delta](\circ\circ\circ)$ $[(\circ\circ\circ)](\circ\Delta)$ $[\circ\circ\circ](\circ\Delta)$ $[(\circ\Delta)](\circ\circ\circ)$
 $[\circ\Delta][\circ\circ\circ)$ $[(\circ\Delta)][\circ\circ\circ)$ $[\circ\Delta][(\circ\circ\circ)]$ $[(\circ\circ\circ)][\circ\Delta]$ $[\circ\circ\circ][(\circ\Delta)]$ $[(\circ\Delta)][(\circ\circ\circ)]$
 $[\circ\Delta][\circ\circ\circ]$ $[(\circ\Delta)][\circ\circ\circ]$ $[\circ\Delta][(\circ\circ\circ)]$ $[(\circ\circ\circ)][\circ\Delta]$ $[\circ\circ\circ][(\circ\Delta)]$ $[(\circ\Delta)][(\circ\circ\circ)]$.

Semiotisches System

$(1.3)(2.1)$ $((1.3))(2.1)$ $(1.3)((2.1))$ $((2.1))(1.3)$ $(2.1)((1.3))$ $((1.3))((2.1))$
 $(1.3)(2.1)$ $((1.3))(2.1)$ $(1.3)((2.1))$ $((2.1))(1.3)$ $(2.1)((1.3))$ $((1.3))((2.1))$
 $(1.3)[2.1)$ $((1.3))[2.1)$ $(1.3)[(2.1)]$ $((2.1))[1.3)$ $(2.1)[(1.3)]$ $((1.3))[2.1)$
 $(1.3)[2.1)$ $((1.3))[2.1)$ $(1.3)[(2.1)]$ $((2.1))[1.3)$ $(2.1)[(1.3)]$ $((1.3))[2.1)$

$(1.3](2.1)$ $((1.3)](2.1)$ $(1.3]((2.1))$ $((2.1)](1.3)$ $(2.1]((1.3))$ $((1.3)]((2.1))$
 $(1.3](2.1)$ $((1.3)](2.1)$ $(1.3]((2.1))$ $((2.1)](1.3)$ $(2.1]((1.3))$ $(1.3]((2.1))$
 $(1.3][2.1)$ $((1.3)][2.1)$ $(1.3][2.1)$ $((2.1)][1.3)$ $(2.1][1.3)$ $((1.3)][2.1)$
 $(1.3][2.1)$ $((1.3)][2.1)$ $(1.3][2.1)$ $((2.1)][1.3)$ $(2.1][1.3)$ $((1.3)][2.1)$

$[1.3)(2.1)$ $[(1.3))(2.1)$ $[1.3)((2.1))$ $[(2.1))(1.3)$ $[2.1)((1.3))$ $[(1.3))((2.1))$
 $[1.3)(2.1)$ $[(1.3))(2.1)$ $[1.3)((2.1))$ $[(2.1))(1.3)$ $[2.1)((1.3))$ $[(1.3))((2.1))$
 $[1.3)[2.1)$ $[(1.3)[2.1)$ $[1.3][2.1)$ $[(2.1)[1.3)$ $[2.1][1.3)$ $[(1.3)[2.1)$
 $[1.3)[2.1)$ $[(1.3)[2.1)$ $[1.3][2.1)$ $[(2.1)[1.3)$ $[2.1][1.3)$ $[(1.3)[2.1)$

$[1.3](2.1)$ $[(1.3)](2.1)$ $[1.3]((2.1))$ $[(2.1)](1.3)$ $[2.1]((1.3))$ $[(1.3)]((2.1))$
 $[1.3](2.1)$ $[(1.3)](2.1)$ $[1.3]((2.1))$ $[(2.1)](1.3)$ $[2.1]((1.3))$ $[(1.3)]((2.1))$
 $[1.3][2.1)$ $[(1.3)][2.1)$ $[1.3][2.1)$ $[(2.1)][1.3)$ $[2.1][1.3)$ $[(1.3)][2.1)$
 $[1.3][2.1)$ $[(1.3)][2.1)$ $[1.3][2.1)$ $[(2.1)][1.3)$ $[2.1][1.3)$ $[(1.3)][2.1)$

R*-System

Ontisches System

$(Sys)(Obj)$ $((Sys))(Obj)$ $(Sys)((Obj))$ $((Obj))(Sys)$ $(Obj)((Sys))$ $((Sys))((Obj))$
 $(Sys)(Obj]$ $((Sys))(Obj]$ $(Sys)((Obj])$ $((Obj))(Sys]$ $(Obj)((Sys])$ $((Sys))((Obj])$
 $(Sys)[Obj)$ $((Sys))[Obj)$ $(Sys)[(Obj)]$ $((Obj))[Sys)$ $(Obj)[(Sys))$ $((Sys))[Obj)$
 $(Sys)[Obj]$ $((Sys))[Obj]$ $(Sys)[(Obj)]$ $((Obj))[Sys]$ $(Obj)[(Sys)]$ $((Sys))[Obj]$

$(Sys](Obj)$ $((Sys)](Obj)$ $(Sys]((Obj))$ $((Obj)](Sys)$ $(Obj]((Sys))$ $((Sys)]((Obj))$
 $(Sys](Obj]$ $((Sys)](Obj]$ $(Sys]((Obj])$ $((Obj)](Sys]$ $(Obj]((Sys])$ $(Sys]((Obj])$
 $(Sys][Obj)$ $((Sys)][Obj)$ $(Sys][2.1)$ $((Obj)][Sys)$ $(Obj][1.3)$ $((Sys)][Obj)$
 $(Sys][Obj]$ $((Sys)][Obj]$ $(Sys][2.1)$ $((Obj)][Sys]$ $(Obj][1.3)]$ $((Sys)][Obj]$

[Sys)(Obj)	[(Sys))(Obj)	[Sys)((Obj))	[(Obj))(Sys)	[Obj)((Sys))	[(Sys))((Obj))
[Sys)(Obj]	[(Sys))(Obj]	[Sys)((Obj)]	[(Obj))(Sys]	[Obj)((Sys)]	[(Sys))((Obj)]
[Sys][Obj)	[(Sys))[Obj)	[Sys]((Obj))	[(Obj)][Sys)	[Obj]((Sys))	[(Sys)][(Obj))
[Sys][Obj]	[(Sys))[Obj]	[Sys]((Obj)]	[(Obj)][Sys]	[Obj]((Sys)]	[(Sys)][(Obj)]

[Sys](Obj)	[(Sys)](Obj)	[Sys]((Obj))	[(Obj)](Sys)	[Obj]((Sys))	[(Sys)]((Obj))
[Sys](Obj]	[(Sys)](Obj]	[Sys]((Obj)]	[(Obj)](Sys]	[Obj]((Sys)]	[(Sys)]((Obj)]
[Sys][Obj)	[(Sys)][Obj)	[Sys]((Obj))	[(Obj)][Sys)	[Obj]((Sys))	[(Sys)][(Obj))
[Sys][Obj]	[(Sys)][Obj]	[Sys]((Obj)]	[(Obj)][Sys]	[Obj]((Sys)]	[(Sys)][(Obj)]

Kenogrammatisches System

(ooo)(oΔ)	((ooo))(oΔ)	(ooo)((oΔ))	((oΔ))(ooo)	(oΔ)((ooo))	((ooo))((oΔ))
(ooo)(oΔ]	((ooo))(oΔ]	(ooo)((oΔ)]	((oΔ))(ooo]	(oΔ)((ooo)]	((ooo))((oΔ)]
(ooo)[oΔ)	((ooo))[oΔ)	(ooo)[(oΔ))	((oΔ))[ooo)	(oΔ)[(ooo))	((ooo))[oΔ))
(ooo)[oΔ]	((ooo))[oΔ]	(ooo)[(oΔ)]	((oΔ))[ooo]	(oΔ)[(ooo)]	((ooo))[oΔ]

(ooo](oΔ)	((ooo)](oΔ)	(ooo]((oΔ))	((oΔ)](ooo)	(oΔ]((ooo))	((ooo)]((oΔ))
(ooo](oΔ]	((ooo)](oΔ]	(ooo]((oΔ)]	((oΔ)](ooo]	(oΔ]((ooo)]	((ooo)]((oΔ)]
(ooo][oΔ)	((ooo)][oΔ)	(ooo][oΔ))	((oΔ)][ooo)	(oΔ][oΔ))	((ooo)][oΔ))
(ooo][oΔ]	((ooo)][oΔ]	(ooo][oΔ)]	((oΔ)][ooo]	(oΔ][oΔ)]	((ooo)][oΔ]

[ooo)(oΔ)	[(ooo))(oΔ)	[ooo)((oΔ))	[(oΔ))(ooo)	[oΔ)((ooo))	[(ooo))((oΔ))
[ooo)(oΔ]	[(ooo))(oΔ]	[ooo)((oΔ)]	[(oΔ))(ooo]	[oΔ)((ooo)]	[(ooo))((oΔ)]
[ooo][oΔ)	[(ooo))[oΔ)	[ooo][oΔ))	[(oΔ))[ooo)	[oΔ][oΔ))	[(ooo))[oΔ))
[ooo][oΔ]	[(ooo))[oΔ]	[ooo][oΔ)]	[(oΔ))[ooo]	[oΔ][oΔ)]	[(ooo))[oΔ]

[ooo](oΔ)	[(ooo)](oΔ)	[ooo]((oΔ))	[(oΔ)](ooo)	[oΔ]((ooo))	[(ooo)]((oΔ))
[ooo](oΔ]	[(ooo)](oΔ]	[ooo]((oΔ)]	[(oΔ)](ooo]	[oΔ]((ooo)]	[(ooo)]((oΔ)]
[ooo][oΔ)	[(ooo)][oΔ)	[ooo][oΔ))	[(oΔ)][ooo)	[oΔ][oΔ))	[(ooo)][oΔ))
[ooo][oΔ]	[(ooo)][oΔ]	[ooo][oΔ)]	[(oΔ)][ooo]	[oΔ][oΔ)]	[(ooo)][oΔ]

Semiotisches System

(2.1)(1.3)	((2.1))(1.3)	(2.1)((1.3))	((1.3))(2.1)	(1.3)((2.1))	((2.1))((1.3))
(2.1)(1.3]	((2.1))(1.3]	(2.1)((1.3)]	((1.3))(2.1]	(1.3)((2.1)]	((2.1))((1.3)]
(2.1)[1.3)	((2.1))[1.3)	(2.1)[(1.3))	((1.3))[2.1)	(1.3)[(2.1))	((2.1))[1.3))
(2.1)[1.3]	((2.1))[1.3]	(2.1)[(1.3)]	((1.3))[2.1]	(1.3)[(2.1)]	((2.1))[1.3]

(2.1](1.3)	((2.1)](1.3)	(2.1]((1.3))	((1.3)](2.1)	(1.3]((2.1))	((2.1)]((1.3))
(2.1](1.3]	((2.1)](1.3]	(2.1]((1.3)]	((1.3)](2.1]	(1.3]((2.1)]	(2.1]((1.3)]
(2.1][1.3)	((2.1)][1.3)	(2.1][1.3))	((1.3)][2.1)	(1.3][2.1))	((2.1)][1.3))
(2.1][1.3]	((2.1)][1.3]	(2.1][1.3)]	((1.3)][2.1]	(1.3][2.1)]	((2.1)][1.3]

[2.1)(1.3) [(2.1))(1.3) [2.1)((1.3)) [(1.3))(2.1) [1.3)((2.1)) [(2.1))((1.3))
 [2.1)(1.3) [(2.1))(1.3) [2.1)((1.3)) [(1.3))(2.1) [1.3)((2.1)) [(2.1))((1.3))
 [2.1)[1.3) [(2.1))[1.3) [2.1)[(1.3)] [(1.3)][2.1) [1.3)[(2.1)] [(2.1)][(1.3)]
 [2.1)[1.3) [(2.1))[1.3) [2.1)[(1.3)] [(1.3)][2.1) [1.3)[(2.1)] [(2.1)][(1.3)]

[2.1](1.3) [(2.1)](1.3) [2.1]((1.3)) [(1.3)](2.1) [1.3]((2.1)) [(2.1)]((1.3))
 [2.1](1.3) [(2.1)](1.3) [2.1]((1.3)) [(1.3)](2.1) [1.3]((2.1)) [(2.1)]((1.3))
 [2.1][1.3) [(2.1)][1.3) [2.1][(1.3)] [(1.3)][2.1) [1.3][(2.1)] [(2.1)][(1.3)]
 [2.1][1.3) [(2.1)][1.3) [2.1][(1.3)] [(1.3)][2.1) [1.3][(2.1)] [(2.1)][(1.3)]

2.8. (1.3, 2.2)-System

R-System

Ontisches System

(Obj)(Abb) ((Obj))(Abb) (Obj)((Abb)) ((Abb))(Obj) (Abb)((Obj)) ((Obj))((Abb))
 (Obj)(Abb) ((Obj))(Abb) (Obj)((Abb)) ((Abb))(Obj) (Abb)((Obj)) ((Obj))((Abb))
 (Obj)[Abb) ((Obj))[Abb) (Obj)[(Abb)] ((Abb))[Obj) (Abb)[(Obj)] ((Obj))[Abb)
 (Obj)[Abb) ((Obj))[Abb) (Obj)[(Abb)] ((Abb))[Obj) (Abb)[(Obj)] ((Obj))[Abb)

(Obj](Abb) ((Obj)](Abb) (Obj]((Abb)) ((Abb)](Obj) (Abb]((Obj)) ((Obj)]((Abb))
 (Obj](Abb) ((Obj)](Abb) (Obj]((Abb)) ((Abb)](Obj) (Abb]((Obj)) (Obj]((Abb))
 (Obj][Abb) ((Obj)][Abb) (Obj][[(Abb)] ((Abb)][Obj) (Abb][[(Obj)] ((Obj)][Abb)
 (Obj][Abb) ((Obj)][Abb) (Obj][[(Abb)] ((Abb)][Obj) (Abb][[(Obj)] ((Obj)][Abb)

[Obj)(Abb) [(Obj))(Abb) [Obj)((Abb)) [(Abb))(Obj) [Abb)((Obj)) [(Obj))((Abb))
 [Obj)(Abb) [(Obj))(Abb) [Obj)((Abb)) [(Abb))(Obj) [Abb)((Obj)) [(Obj))((Abb))
 [Obj][Abb) [(Obj)][Abb) [Obj)[(Abb)] [(Abb)][Obj) [Abb)[(Obj)] [(Obj)][Abb)
 [Obj][Abb) [(Obj)][Abb) [Obj)[(Abb)] [(Abb)][Obj) [Abb)[(Obj)] [(Obj)][Abb)

[Obj](Abb) [(Obj)](Abb) [Obj]((Abb)) [(Abb)](Obj) [Abb]((Obj)) [(Obj)]((Abb))
 [Obj](Abb) [(Obj)](Abb) [Obj]((Abb)) [(Abb)](Obj) [Abb]((Obj)) [(Obj)]((Abb))
 [Obj][Abb) [(Obj)][Abb) [Obj][[(Abb)] [(Abb)][Obj) [Abb][[(Obj)] [(Obj)][Abb)
 [Obj][Abb) [(Obj)][Abb) [Obj][[(Abb)] [(Abb)][Obj) [Abb][[(Obj)] [(Obj)][Abb).

Kenogrammatisches System

(◊△)(◊◊△) ((◊△))(◊◊△)(◊△)((◊◊△))((◊◊△))(◊△)(◊◊△)((◊△))((◊△))((◊◊△))

Ontisches System

(Abb)(Obj) ((Abb))(Obj) (Abb)((Obj)) ((Obj))(Abb) (Obj)((Abb)) ((Abb))((Obj))
 (Abb)(Obj] ((Abb))(Obj] (Abb)((Obj]) ((Obj])(Abb) (Obj)((Abb]) ((Abb))((Obj])
 (Abb)[Obj) ((Abb))[Obj) (Abb)[(Obj)) ((Obj))[Abb) (Obj)[(Abb)) ((Abb))[Obj))
 (Abb)[Obj] ((Abb))[Obj] (Abb)[(Obj)] ((Obj))[Abb] (Obj)[(Abb)] ((Abb))[Obj]

(Abb](Obj) ((Abb)](Obj) (Abb]((Obj)) ((Obj)](Abb) (Obj]((Abb)) ((Abb)]((Obj))
 (Abb](Obj] ((Abb)](Obj] (Abb]((Obj]) ((Obj)](Abb) (Obj]((Abb]) (Abb]((Obj])
 (Abb])[Obj) ((Abb])[Obj) (Abb])[Obj)) ((Obj])[Abb) (Obj])[Obj)) ((Abb])[Obj))
 (Abb])[Obj] ((Abb])[Obj] (Abb])[Obj)] ((Obj])[Abb] (Obj])[Obj)] ((Abb])[Obj]

[Abb)(Obj) [(Abb))(Obj) [Abb]((Obj)) [(Obj))(Abb) [Obj]((Abb)) [(Abb))((Obj))
 [Abb)(Obj] [(Abb))(Obj] [Abb]((Obj]) [(Obj))(Abb) [Obj]((Abb]) [(Abb))((Obj])
 [Abb][Obj) [(Abb))[Obj) [Abb][Obj)) ((Obj))[Abb) [Obj][Obj)) ((Abb))[Obj))
 [Abb][Obj] [(Abb))[Obj] [Abb][Obj)] ((Obj))[Abb] [Obj][Obj)] ((Abb))[Obj]

[Abb](Obj) [(Abb)](Obj) [Abb]((Obj)) [(Obj)](Abb) [Obj]((Abb)) [(Abb)]((Obj))
 [Abb](Obj] [(Abb)](Obj] [Abb]((Obj]) [(Obj)](Abb) [Obj]((Abb]) [(Abb)]((Obj])
 [Abb][Obj) [(Abb)](Obj) [Abb][Obj)) ((Obj)](Abb) [Obj][Obj)) [(Abb)](Obj))
 [Abb][Obj] [(Abb)](Obj] [Abb][Obj)] ((Obj)](Abb) [Obj][Obj)] [(Abb)](Obj]

Kenogrammatisches System

(○○△)(○△)((○○△))(○△)(○○△)((○△))((○△))(○○△)(○△)((○○△)) ((○○△))((○△))
 (○○△)(○△] ((○○△))(○△](○○△)((○△)]((○△))(○○△](○△)((○○△)]((○○△))((○△)]
 (○○△)[○△) ((○○△))[○△)(○○△)[(○△))((○△))[○○△](○△)[(○○△))((○○△))[○△))
 (○○△)[○△] ((○○△))[○△](○○△)(○△)[○○△](○△)(○○△)[○△]

(○○△](○△) ((○○△)](○△)(○○△]((○△))((○△)](○○△)(○△]((○○△))((○○△)]((○△))
 (○○△](○△] ((○○△)](○△](○○△]((○△)]((○△)](○○△](○△]((○○△)](○○△]((○△)]
 (○○△][○△) ((○○△)](○△)(○○△][○△))((○△)](○○△)(○△][○△))((○○△)](○△))
 (○○△][○△] ((○○△)](○△](○○△][○△)]((○△)](○○△)(○△][○△)]((○○△)](○△)]

[○○△)(○△) [(○○△))(○△)[○○△]((○△))[(○△))(○○△)[○△]((○○△))[(○○△))((○△))
 [○○△)(○△] [(○○△))(○△][○○△]((○△)][(○△))(○○△)[○△]((○○△))[(○○△))((○△)]
 [○○△][○△) [(○○△))[○△][○○△]((○△))[(○△))[○○△][○△]((○○△))[(○○△)](○△))
 [○○△][○△] [(○○△))[○△][○○△]((○△)][(○△))[○○△][○△]((○○△))[(○○△)](○△)]

[○○△](○△) [(○○△)](○△)[○○△]((○△))[(○△)](○○△)[○△]((○○△))[(○○△)]((○△))
 [○○△](○△] [(○○△)](○△][○○△]((○△)][(○△)](○○△)[○△]((○○△))[(○○△)]((○△)]
 [○○△][○△) [(○○△)](○△)[○○△]((○△))[(○△)](○○△)[○△]((○○△))[(○○△)](○△))
 [○○△][○△] [(○○△)](○△][○○△]((○△)][(○△)](○○△)[○△]((○○△))[(○○△)](○△)]

Semiotisches System

(2.2)(1.3)	((2.2))(1.3)	(2.2)((1.3))	((1.3))(2.2)	(1.3)((2.2))	((2.2))((1.3))
(2.2)[1.3]	((2.2))[1.3]	(2.2)[(1.3)]	((1.3))[2.2]	(1.3)[(2.2)]	((2.2))[(1.3)]
(2.2)(1.3)	((2.2)](1.3)	(2.2)((1.3))	((1.3)](2.2)	(1.3)((2.2))	((2.2))[(1.3)]
(2.2)[1.3]	((2.2)](1.3)	(2.2)[(1.3)]	((1.3)](2.2)	(1.3)[(2.2)]	((2.2))[(1.3)]
[2.2)(1.3)	[(2.2))(1.3)	[2.2)((1.3))	[(1.3))(2.2)	[1.3)((2.2))	[(2.2))((1.3))
[2.2)(1.3]	[(2.2))(1.3]	[2.2)((1.3)]	[(1.3))(2.2]	[1.3)((2.2)]	[(2.2))((1.3)]
[2.2)[1.3)	[(2.2)][1.3)	[2.2][(1.3))	[(1.3)][2.2)	[1.3][(2.2))	[(2.2)][(1.3))
[2.2)[1.3]	[(2.2)][1.3]	[2.2][(1.3)]	[(1.3)][2.2]	[1.3][(2.2)]	[(2.2)][(1.3)]
[2.2](1.3)	[(2.2)](1.3)	[2.2]((1.3))	[(1.3)](2.2)	[1.3]((2.2))	[(2.2)]((1.3))
[2.2](1.3]	[(2.2)](1.3]	[2.2]((1.3)]	[(1.3)](2.2]	[1.3]((2.2)]	[2.2]((1.3)]
[2.2][1.3)	[(2.2)][1.3)	[2.2][(1.3))	[(1.3)][2.2)	[1.3][(2.2))	[(2.2)][(1.3))
[2.2][1.3]	[(2.2)][1.3]	[2.2][(1.3)]	[(1.3)][2.2]	[1.3][(2.2)]	[(2.2)][(1.3)]

2.9. (1.3, 2.3)-System

R-System

Ontisches System

(Obj)(Rep)	((Obj))(Rep)	(Obj)((Rep))	((Rep))(Obj)	(Rep)((Obj))	((Obj))((Rep))
(Obj)(Rep]	((Obj))(Rep]	(Obj)((Rep)]	((Rep))(Obj]	(Rep)((Obj)]	((Obj))((Rep)]
(Obj)[Rep)	((Obj))[Rep)	(Obj)[(Rep))	((Rep))[Obj)	(Rep)[(Obj))	((Obj))[Rep))
(Obj)[Rep]	((Obj))[Rep]	(Obj)[(Rep)]	((Rep))[Obj]	(Rep)[(Obj)]	((Obj))[Rep]
(Obj](Rep)	((Obj)](Rep)	(Obj]((Rep))	((Rep)](Obj)	(Rep]((Obj))	((Obj)]((Rep))
(Obj](Rep]	((Obj)](Rep]	(Obj]((Rep)]	((Rep)](Obj]	(Rep]((Obj)]	(Obj]((Rep)]
(Obj][Rep)	((Obj)][Rep)	(Obj][Rep))	((Rep)][Obj)	(Rep][Obj))	((Obj)][Rep))
(Obj][Rep]	((Obj)][Rep]	(Obj][Rep)]	((Rep)][Obj]	(Rep][Obj)]	((Obj)][Rep]
[Obj)(Rep)	[(Obj))(Rep)	[Obj)((Rep))	[(Rep))(Obj)	[Rep)((Obj))	[(Obj))((Rep))
[Obj)(Rep]	[(Obj))(Rep]	[Obj)((Rep)]	[(Rep))(Obj]	[Rep)((Obj)]	[(Obj))((Rep)]
[Obj)[Rep)	[(Obj)][Rep)	[Obj][(Rep))	[(Rep)][Obj)	[Rep][(Obj))	[(Obj)][Rep))
[Obj)[Rep]	[(Obj)][Rep]	[Obj][(Rep)]	[(Rep)][Obj]	[Rep][(Obj)]	[(Obj)][Rep]

[Obj](Rep) [(Obj)](Rep) [Obj]((Rep)) [(Rep)](Obj) [Rep]((Obj)) [(Obj)]((Rep))
 [Obj](Rep) [(Obj)](Rep) [Obj]((Rep)) [(Rep)](Obj) [Rep]((Obj)) [(Obj)]((Rep))
 [Obj][Rep] [(Obj)][Rep] [Obj]([Rep]) [(Rep)][Obj] [Rep]([Obj]) [(Obj)]([Rep])
 [Obj][Rep] [(Obj)][Rep] [Obj]([Rep]) [(Rep)][Obj] [Rep]([Obj]) [(Obj)]([Rep]).

Kenogrammatisches System

(◊Δ)(◊Δ□)((◊Δ))(◊Δ□(◊Δ)((◊Δ□))((◊Δ□))(◊Δ)(◊Δ□)((◊Δ)) ((◊Δ))((◊Δ□))
 (◊Δ)(◊Δ□)((◊Δ))(◊Δ□(◊Δ)((◊Δ□))((◊Δ□))(◊Δ)(◊Δ□)((◊Δ)) ((◊Δ))((◊Δ□)]
 (◊Δ)[◊Δ□] ((◊Δ))[◊Δ□(◊Δ)[(◊Δ□))((◊Δ□)]◊Δ(◊Δ□)[(◊Δ))((◊Δ))[◊Δ□]
 (◊Δ)[◊Δ□] ((◊Δ))[◊Δ□(◊Δ)[(◊Δ□)]((◊Δ□)]◊Δ(◊Δ□)(◊Δ)[◊Δ□]

(◊Δ](◊Δ□] ((◊Δ)](◊Δ□(◊Δ)]((◊Δ□))((◊Δ□)](◊Δ)(◊Δ□]((◊Δ))((◊Δ)]((◊Δ□))
 (◊Δ](◊Δ□] ((◊Δ)](◊Δ□(◊Δ)]((◊Δ□)]((◊Δ□)](◊Δ](◊Δ□]((◊Δ)](◊Δ)]((◊Δ□)]
 (◊Δ][◊Δ□] ((◊Δ)](◊Δ□(◊Δ)]((◊Δ□))((◊Δ□)]◊Δ(◊Δ□]((◊Δ))((◊Δ)]((◊Δ□))
 (◊Δ][◊Δ□] ((◊Δ)](◊Δ□(◊Δ)]((◊Δ□)]((◊Δ□)]◊Δ(◊Δ□]((◊Δ)]((◊Δ)]((◊Δ□)]

[◊Δ)(◊Δ□] [(◊Δ))(◊Δ□[◊Δ]((◊Δ□))[(◊Δ□))(◊Δ)[◊Δ□]((◊Δ))[(◊Δ)]((◊Δ□))
 [◊Δ)(◊Δ□] [(◊Δ))(◊Δ□[◊Δ]((◊Δ□))[(◊Δ□))(◊Δ)[◊Δ□]((◊Δ))[(◊Δ)]((◊Δ□)]
 [◊Δ][◊Δ□] [(◊Δ)][◊Δ□[◊Δ]((◊Δ□))[(◊Δ□)]◊Δ[◊Δ□]((◊Δ))[(◊Δ)]((◊Δ□))
 [◊Δ][◊Δ□] [(◊Δ)][◊Δ□[◊Δ]((◊Δ□))[(◊Δ□)]◊Δ[◊Δ□]((◊Δ)]((◊Δ)]((◊Δ□)]

[◊Δ](◊Δ□] [(◊Δ)](◊Δ□[◊Δ]((◊Δ□))[(◊Δ□)](◊Δ)[◊Δ□]((◊Δ))[(◊Δ)]((◊Δ□))
 [◊Δ](◊Δ□] [(◊Δ)](◊Δ□[◊Δ]((◊Δ□))[(◊Δ□)](◊Δ)[◊Δ□]((◊Δ))[(◊Δ)]((◊Δ□)]
 [◊Δ][◊Δ□] [(◊Δ)](◊Δ□[◊Δ]((◊Δ□))[(◊Δ□)]◊Δ[◊Δ□]((◊Δ))[(◊Δ)]((◊Δ□))
 [◊Δ][◊Δ□] [(◊Δ)](◊Δ□[◊Δ]((◊Δ□))[(◊Δ□)]◊Δ[◊Δ□]((◊Δ)]((◊Δ)]((◊Δ□)].

Semiotisches System

(1.3)(2.3) ((1.3))(2.3) (1.3)((2.3)) ((2.3))(1.3) (2.3)((1.3)) ((1.3))((2.3))
 (1.3)(2.3) ((1.3))(2.3) (1.3)((2.3)] ((2.3))(1.3) (2.3)((1.3)] ((1.3))((2.3)]
 (1.3)[2.3] ((1.3))[2.3] (1.3)[(2.3)] ((2.3)][1.3] (2.3)[(1.3)] ((1.3))[(2.3)]
 (1.3)[2.3] ((1.3))[2.3] (1.3)[(2.3)] ((2.3)][1.3] (2.3)[(1.3)] ((1.3))[(2.3)]

(1.3](2.3] ((1.3)](2.3] (1.3]((2.3)) ((2.3)](1.3] (2.3]((1.3]) ((1.3)]((2.3])
 (1.3](2.3] ((1.3)](2.3] (1.3]((2.3)] ((2.3)](1.3] (2.3]((1.3)] (1.3]((2.3)]
 (1.3][2.3] ((1.3)](2.3] (1.3]((2.3)] ((2.3)](1.3] (2.3]((1.3)] ((1.3)]((2.3)]
 (1.3][2.3] ((1.3)](2.3] (1.3]((2.3)] ((2.3)](1.3] (2.3]((1.3)] ((1.3)]((2.3)]

[1.3)(2.3] [(1.3))(2.3] [1.3]((2.3)) [(2.3)](1.3) [2.3]((1.3)) [(1.3)]((2.3))
 [1.3)(2.3] [(1.3))(2.3] [1.3]((2.3)] [(2.3)](1.3) [2.3]((1.3)] [(1.3)]((2.3)]
 [1.3][2.3] [(1.3)](2.3] [1.3]((2.3)] [(2.3)][1.3] [2.3]((1.3)] [(1.3)]((2.3)]

[1.3][2.3] [(1.3)][2.3] [1.3][(2.3)] [(2.3)][1.3] [2.3][(1.3)] [(1.3)][(2.3)]

[1.3](2.3) [(1.3)](2.3) [1.3]((2.3)) [(2.3)](1.3) [2.3]((1.3)) [(1.3)]((2.3))

[1.3][2.3] [(1.3)][2.3] [1.3][(2.3)] [(2.3)][1.3] [2.3][(1.3)] [(1.3)][(2.3)]

[1.3][2.3] [(1.3)][2.3] [1.3][(2.3)] [(2.3)][1.3] [2.3][(1.3)] [(1.3)][(2.3)]

[1.3][2.3] [(1.3)][2.3] [1.3][(2.3)] [(2.3)][1.3] [2.3][(1.3)] [(1.3)][(2.3)].

R*-System

Ontisches System

(Rep)(Obj) ((Rep))(Obj) (Rep)((Obj)) ((Obj))(Rep) (Obj)((Rep)) ((Rep))((Obj))

(Rep)(Obj) ((Rep))(Obj] (Rep)((Obj)] ((Obj))(Rep] (Obj)((Rep] ((Rep))((Obj)]

(Rep)[Obj] ((Rep))[Obj] (Rep)[(Obj)] ((Obj))[Rep] (Obj)[(Rep)] ((Rep))[Obj]

(Rep)[Obj] ((Rep))[Obj] (Rep)[(Obj)] ((Obj))[Rep] (Obj)[(Rep)] ((Rep))[Obj]

(Rep](Obj) ((Rep)](Obj) (Rep]((Obj)) ((Obj)](Rep) (Obj]((Rep)) ((Rep)]((Obj))

(Rep](Obj] ((Rep)](Obj] (Rep]((Obj)] ((Obj)](Rep] (Obj]((Rep] (Rep]((Obj)]

(Rep] [Obj] ((Rep] [Obj] (Rep] [(Obj)] ((Obj] [Rep] (Obj] [(Rep]) ((Rep] [Obj])

(Rep] [Obj] ((Rep] [Obj] (Rep] [(Obj)] ((Obj] [Rep] (Obj] [(Rep]) ((Rep] [Obj])

[Rep)(Obj) [(Rep))(Obj) [Rep]((Obj)) [(Obj))(Rep] [Obj]((Rep)) [(Rep))((Obj))

[Rep)(Obj] [(Rep))(Obj] [Rep]((Obj)] [(Obj))(Rep] [Obj]((Rep)] [(Rep))((Obj)]

[Rep][Obj] [(Rep))[Obj] [Rep][(Obj)] [(Obj))[Rep] [Obj][(Rep)] [(Rep))[Obj]

[Rep][Obj] [(Rep))[Obj] [Rep][(Obj)] [(Obj))[Rep] [Obj][(Rep)] [(Rep))[Obj]

[Rep](Obj) [(Rep)](Obj) [Rep]((Obj)) [(Obj)](Rep) [Obj]((Rep)) [(Rep)]((Obj))

[Rep](Obj] [(Rep)](Obj] [Rep]((Obj)] [(Obj)](Rep] [Obj]((Rep)] [(Rep)]((Obj)]

[Rep][Obj] [(Rep)][Obj] [Rep][(Obj)] [(Obj)] [Rep] [Obj][(Rep)] [(Rep)][Obj]

[Rep][Obj] [(Rep)][Obj] [Rep][(Obj)] [(Obj)] [Rep] [Obj][(Rep)] [(Rep)][Obj]

Kenogrammatisches System

(◊△□)(◊△)((◊△□))(◊△)(◊△□)((◊△))((◊△))(◊△□)(◊△)((◊△□)) ((◊△□))((◊△))

(◊△□)(◊△] ((◊△□))(◊△](◊△□)((◊△)]((◊△))(◊△□)(◊△)((◊△□)]((◊△□))((◊△)]

(◊△□)[◊△] ((◊△□))[◊△](◊△□)(◊△)[◊△□)(◊△)[(◊△□))((◊△□))[◊△]

(◊△□)[◊△] ((◊△□))[◊△](◊△□)(◊△)[◊△□)(◊△)(◊△□)[◊△]

(◊△□](◊△) ((◊△□)](◊△)(◊△□]((◊△))((◊△)](◊△□)(◊△]((◊△□))((◊△□)]((◊△))

(◊△□](◊△] ((◊△□)](◊△](◊△□]((◊△)]((◊△)](◊△□](◊△]((◊△□)](◊△□]((◊△)]

(◊△□][◊△] ((◊△□)][◊△](◊△□][(◊△)]((◊△)] [◊△□](◊△][(◊△□)]((◊△□)] [◊△])

(◊△□][◊△] ((◊△□)][◊△](◊△□][(◊△)]((◊△)] [◊△□](◊△][(◊△□)]((◊△□)] [◊△])

$[\circ\Delta\Box](\circ\Delta)$ $[(\circ\Delta\Box)](\circ\Delta)$ $[\circ\Delta\Box](\circ\Delta)$ $[(\circ\Delta\Box)](\circ\Delta)$ $[(\circ\Delta\Box)](\circ\Delta)$ $[(\circ\Delta\Box)](\circ\Delta)$ $[(\circ\Delta\Box)](\circ\Delta)$ $[(\circ\Delta\Box)](\circ\Delta)$
 $[\circ\Delta\Box](\circ\Delta)$ $[(\circ\Delta\Box)](\circ\Delta)$ $[\circ\Delta\Box](\circ\Delta)$ $[(\circ\Delta\Box)](\circ\Delta)$ $[(\circ\Delta\Box)](\circ\Delta)$ $[(\circ\Delta\Box)](\circ\Delta)$ $[(\circ\Delta\Box)](\circ\Delta)$ $[(\circ\Delta\Box)](\circ\Delta)$
 $[\circ\Delta\Box](\circ\Delta)$ $[(\circ\Delta\Box)](\circ\Delta)$ $[\circ\Delta\Box](\circ\Delta)$ $[(\circ\Delta\Box)](\circ\Delta)$ $[(\circ\Delta\Box)](\circ\Delta)$ $[(\circ\Delta\Box)](\circ\Delta)$ $[(\circ\Delta\Box)](\circ\Delta)$ $[(\circ\Delta\Box)](\circ\Delta)$
 $[\circ\Delta\Box](\circ\Delta)$ $[(\circ\Delta\Box)](\circ\Delta)$ $[\circ\Delta\Box](\circ\Delta)$ $[(\circ\Delta\Box)](\circ\Delta)$ $[(\circ\Delta\Box)](\circ\Delta)$ $[(\circ\Delta\Box)](\circ\Delta)$ $[(\circ\Delta\Box)](\circ\Delta)$ $[(\circ\Delta\Box)](\circ\Delta)$

$[\circ\Delta\Box](\circ\Delta)$ $[(\circ\Delta\Box)](\circ\Delta)$ $[\circ\Delta\Box](\circ\Delta)$ $[(\circ\Delta\Box)](\circ\Delta)$ $[(\circ\Delta\Box)](\circ\Delta)$ $[(\circ\Delta\Box)](\circ\Delta)$ $[(\circ\Delta\Box)](\circ\Delta)$ $[(\circ\Delta\Box)](\circ\Delta)$
 $[\circ\Delta\Box](\circ\Delta)$ $[(\circ\Delta\Box)](\circ\Delta)$ $[\circ\Delta\Box](\circ\Delta)$ $[(\circ\Delta\Box)](\circ\Delta)$ $[(\circ\Delta\Box)](\circ\Delta)$ $[(\circ\Delta\Box)](\circ\Delta)$ $[(\circ\Delta\Box)](\circ\Delta)$ $[(\circ\Delta\Box)](\circ\Delta)$
 $[\circ\Delta\Box](\circ\Delta)$ $[(\circ\Delta\Box)](\circ\Delta)$ $[\circ\Delta\Box](\circ\Delta)$ $[(\circ\Delta\Box)](\circ\Delta)$ $[(\circ\Delta\Box)](\circ\Delta)$ $[(\circ\Delta\Box)](\circ\Delta)$ $[(\circ\Delta\Box)](\circ\Delta)$ $[(\circ\Delta\Box)](\circ\Delta)$
 $[\circ\Delta\Box](\circ\Delta)$ $[(\circ\Delta\Box)](\circ\Delta)$ $[\circ\Delta\Box](\circ\Delta)$ $[(\circ\Delta\Box)](\circ\Delta)$ $[(\circ\Delta\Box)](\circ\Delta)$ $[(\circ\Delta\Box)](\circ\Delta)$ $[(\circ\Delta\Box)](\circ\Delta)$ $[(\circ\Delta\Box)](\circ\Delta)$

Semiotisches System

$(2.3)(1.3)$ $((2.3))(1.3)$ $(2.3)((1.3))$ $((1.3))(2.3)$ $(1.3)((2.3))$ $((2.3))((1.3))$
 $(2.3)(1.3)$ $((2.3))(1.3)$ $(2.3)((1.3))$ $((1.3))(2.3)$ $(1.3)((2.3))$ $((2.3))((1.3))$
 $(2.3)[1.3]$ $((2.3))[1.3]$ $(2.3)[(1.3)]$ $((1.3))[2.3]$ $(1.3)[(2.3)]$ $((2.3))[1.3]$
 $(2.3)[1.3]$ $((2.3))[1.3]$ $(2.3)[(1.3)]$ $((1.3))[2.3]$ $(1.3)[(2.3)]$ $((2.3))[1.3]$

$(2.3)(1.3)$ $((2.3)](1.3)$ $(2.3)((1.3))$ $((1.3)](2.3)$ $(1.3)((2.3))$ $((2.3))((1.3))$
 $(2.3)(1.3)$ $((2.3)](1.3)$ $(2.3)((1.3))$ $((1.3)](2.3)$ $(1.3)((2.3))$ $(2.3)((1.3))$
 $(2.3)[1.3]$ $((2.3)](1.3)$ $(2.3)[(1.3)]$ $((1.3)](2.3)$ $(1.3)[(2.3)]$ $((2.3)](1.3)$
 $(2.3)[1.3]$ $((2.3)](1.3)$ $(2.3)[(1.3)]$ $((1.3)](2.3)$ $(1.3)[(2.3)]$ $((2.3)](1.3)$

$[2.3](1.3)$ $[(2.3)](1.3)$ $[2.3)((1.3))$ $[(1.3)](2.3)$ $[1.3)((2.3))$ $[(2.3)]((1.3))$
 $[2.3](1.3)$ $[(2.3)](1.3)$ $[2.3)((1.3))$ $[(1.3)](2.3)$ $[1.3)((2.3))$ $[(2.3)]((1.3))$
 $[2.3][1.3]$ $[(2.3)](1.3)$ $[2.3)[(1.3)]$ $[(1.3)](2.3)$ $[1.3)[(2.3)]$ $[(2.3)](1.3)$
 $[2.3][1.3]$ $[(2.3)](1.3)$ $[2.3)[(1.3)]$ $[(1.3)](2.3)$ $[1.3)[(2.3)]$ $[(2.3)](1.3)$

$[2.3](1.3)$ $[(2.3)](1.3)$ $[2.3)((1.3))$ $[(1.3)](2.3)$ $[1.3)((2.3))$ $[(2.3)]((1.3))$
 $[2.3](1.3)$ $[(2.3)](1.3)$ $[2.3)((1.3))$ $[(1.3)](2.3)$ $[1.3)((2.3))$ $[(2.3)]((1.3))$
 $[2.3][1.3]$ $[(2.3)](1.3)$ $[2.3)[(1.3)]$ $[(1.3)](2.3)$ $[1.3)[(2.3)]$ $[(2.3)](1.3)$
 $[2.3][1.3]$ $[(2.3)](1.3)$ $[2.3)[(1.3)]$ $[(1.3)](2.3)$ $[1.3)[(2.3)]$ $[(2.3)](1.3)$

Literatur

Hausdorff, Felix, Zwischen Chaos und Kosmos. 2. Aufl. hrsg. von Max Bense.
 Baden-Baden 1976
 Kronthaler, Engelbert, Zahl – Zeichen – Begriff. In: Semiosis 65-68, 1992, S.
 282-302
 Toth, Alfred, Vollständige und unvollständige ontisch-semiotische Isomor-
 phien I-III. In: Electronic Journal for Mathematical Semiotics, 2014
 Toth, Alfred, Kenogrammatik als Vermittlung zwischen Ontik und Semiotik.
 In: Electronic Journal for Mathematical Semiotics, 2019a

Toth, Alfred, Anfänge einer polykontxturalen Ontik. In: Electronic Journal for Mathematical Semiotics, 2019b

Toth, Alfred, Grundlegung einer polykontexturalen Semiotik. Tucson, AZ, 2019 (= 2019c)

Polykontexturale semiotische Automaten

1. In Toth (2019) hatten wir argumentiert, daß die Definition der drittheitlichen Trichotomie der peirce-benseschen triadisch-trichotomischen Zeichenrelation

$$\text{ZR}_{3,3} = (3.x, 2.y, 1.z)$$

mit ihrer zugehörigen Matrix (vgl. Bense 1975, S. 35 ff.)

	.1	.2	.3
1.	1.1	1.2	1.3
2.	2.1	2.2	2.3
3.	3.1	3.2	3.3

überflüssig und zudem inkonsistent ist, weil sie erstens die logische Subjektposition repräsentiert, aber von Peirce, Bense und Walther (1979) topologisch und logisch definiert wird. Zweitens weil der Zusammenhang von Zeichen ein Problem einer Zeichensyntax, aber keine Eigenschaft des Zeichens selbst ist (vgl. Klaus 1962). Bense selbst hatte das Zeichen wiederholt rein mathematisch definiert, so etwa kategorientheoretisch in (1979, S. 53 u. 67) oder zahlentheoretisch in (1981, S. 17 ff.). Drittens lassen sich die ersten zwei Trichotomien durch

$$(x.1): \quad Z = f(\Omega)$$

$$(x.2): \quad Z = f(\omega, t)$$

$$(x.3): \quad Z \neq f(\Omega)$$

mit $x \in (1, 2)$ definieren, was jedoch für die dritte Trichotomie nicht möglich ist, da der Zusammenhang von Zeichen keine Funktion des Objektes, sondern eine solche einer Menge von Zeichen ist

$$Z = f((Z)).$$

Für den Trivialfall, daß die Menge aus dem Zeichen selbst besteht, gilt dann natürlich

$$Z = f(Z).$$

Es genügt also, von der dyadisch-trichotomischen Zeichenrelation

$$Z_{2,3} = ((w.x), (y.z))$$

mit $w, y \in (1, 2)$ und $x, z \in (1, 2, 3)$ und der zugehörigen Matrix

	.1	.2	.3
1.	1.1	1.2	1.3
2.	2.1	2.2	2.3

auszugehen und jedes Subzeichen der Form

$$S = (x.y)$$

durch

$$(x.1) = f(\Omega)$$

$$(x.2) = f(\omega, t)$$

$$(x.3) \neq f(\Omega)$$

zu definieren.

2. Zelluläre Automaten sind eine Form von autoreproduktiven Automaten (vgl. von Neumann 1966), die zuerst von John H. Conway entdeckt wurden (vgl. Gardner 1970). Ein CA (cellular automata) ist ein Pattern aus 4 Plätzen, die belegt („lebendig“) oder unbelegt („tot“) sein können. CAs werden durch $2^8 = 256$ Regeln bestimmt, durch deren fortgesetzte Anwendung fraktalartige Gebilde entstehen; vgl. als Beispiel den CA der Regel 30.

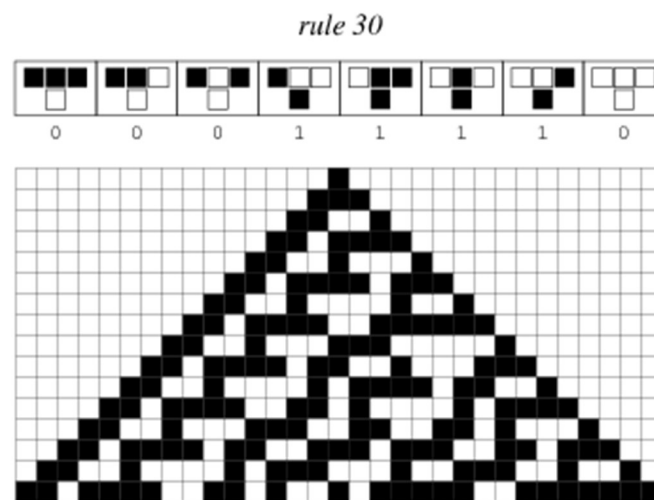

Eine besondere Schwierigkeit bestand darin, CAs für die 15 Basis-Morphogramme der Güntherlogik zu konstruieren. Nach Kaehr (2015a, S. 5) sind die

CAs der Morphogramme in Intra-, Trans-, Inter- und mediative CAs differenzierbar.

Morphograms

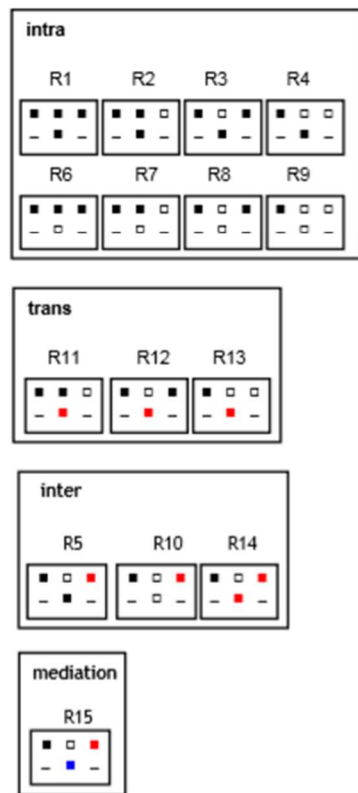

Wie man sieht, genügen die 256 Regeln für quantitative CAs für sog. morpho-CAs nicht mehr. Rudolf Kaehr hat seine letzten Lebensjahre bis zum Tage seines Todes damit verbracht, Regeln zu erzeugen, mit denen Proto-, Deutero- und Trito-Sequenzen als polykontexturale Automaten dargestellt werden können. Das folgende illustrative Beispiel stammt aus Kaehr (2015b, S. 3).

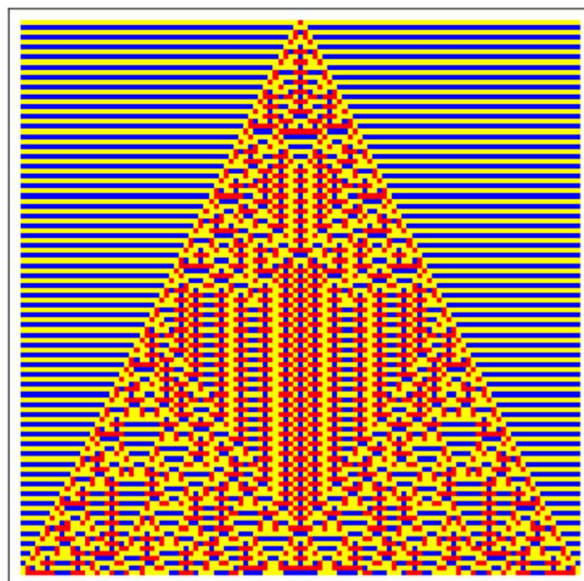

3. Eine besondere Stellung innerhalb der qualitativ-mathematischen CAs nehmen die semiotischen ein, und hier stellen sich noch viel beträchtlichere Schwierigkeiten, denn bei semiotischen CAs gibt es keine unbelegte Zellen. Legt man ZR2,3 zugrunde, dann sind 6 Elemente (Subzeichen) auf 4 Plätze zu verteilen. Man erhält also $\binom{6}{4} = (720 : 2) = 360$ polykontexturale semiotische CAs, die im folgenden numerisch statt durch Farben dargestellt werden. Die 360 semio-CAs sind nach Gruppen von Mengen von Zahlen R geordnet, welche als Input für einen semiotischen CA und dessen Permutationen verwendet werden.

3.1. R = (1, 2, 3, 4)

2	3	4	2	4	3	3	2	4
	1			1			1	
3	4	2	4	2	3	4	3	2
	1			1			1	
1	3	4	1	4	3	3	1	4
	2			2			2	
3	4	1	4	1	3	4	3	1
	2			2			2	
1	2	4	1	4	2	2	1	4
	3			3			3	
2	4	1	4	1	2	4	2	1
	3			3			3	
1	2	3	1	3	2	2	1	3
	4			4			4	
2	3	1	3	1	2	3	2	1
	4			4			4	

3.2. $R = (1, 2, 3, 5)$

2	3	5	2	5	3	3	2	5
	1			1			1	
3	5	2	5	2	3	5	3	2
	1			1			1	
1	3	5	1	5	3	3	1	5
	2			2			2	
3	5	1	5	1	3	5	3	1
	2			2			2	
1	2	5	1	5	2	2	1	5
	3			3			3	
2	5	1	5	1	2	5	2	1
	3			3			3	
1	2	3	1	3	2	2	1	3
	5			5			5	
2	3	1	3	1	2	3	2	1
	5			5			5	

3.3. $R = (1, 2, 3, 6)$

2	3	6	2	6	3	3	2	6
	1			1			1	
3	6	2	6	2	3	6	3	2
	1			1			1	
1	3	6	1	6	3	3	1	6
	2			2			2	

3	6	1	6	1	3	6	3	1
	2			2			2	
1	2	6	1	6	2	2	1	6
	3			3			3	
2	6	1	6	1	2	6	2	1
	3			3			3	
1	2	3	1	3	2	2	1	3
	6			6			6	
2	3	1	3	1	2	3	2	1
	6			6			6	

3.4. $R = (1, 2, 4, 5)$

2	4	5	2	5	4	4	2	5
	1			1			1	
4	5	2	5	2	4	5	4	2
	1			1			1	
1	4	5	1	5	4	4	1	5
	2			2			2	
4	5	1	5	1	4	5	4	1
	2			2			2	
1	2	5	1	5	2	2	1	5
	4			4			4	
2	5	1	5	1	2	5	2	1
	4			4			4	
1	2	4	1	4	2	2	1	4
	5			5			5	
2	4	1	4	1	2	4	2	1

5

5

5

3.5. $R = (1, 2, 4, 6)$

2	4	6	2	6	4	4	2	6
	1			1			1	
4	6	2	6	2	4	6	4	2
	1			1			1	
1	4	6	1	6	4	4	1	6
	2			2			2	
4	6	1	6	1	4	6	4	1
	2			2			2	
1	2	6	1	6	2	2	1	6
	4			4			4	
2	6	1	6	1	2	6	2	1
	4			4			3	
1	2	4	1	4	2	2	1	4
	6			6			6	
2	4	1	4	1	2	4	2	1
	6			6			6	

3.6. $R = (1, 2, 5, 6)$

2	5	6	2	6	5	5	2	6
	1			1			1	
5	6	2	6	2	5	6	5	2
	1			1			1	
1	5	6	1	6	5	5	1	6

2	2	2
5 6 1	6 1 5	6 5 1
2	2	2
1 2 6	1 6 2	2 1 6
5	5	5
2 6 1	6 1 2	6 2 1
5	5	6
1 2 5	1 5 2	2 1 5
6	6	6
2 5 1	5 1 2	5 2 1
6	6	6

3.7. $R = (1, 3, 4, 5)$

3 4 5	3 5 4	4 3 5
1	1	1
4 5 3	5 3 4	5 4 3
1	1	1
1 4 5	1 5 4	4 1 5
3	3	3
4 5 1	5 1 4	5 4 1
3	3	3
1 3 5	1 5 3	3 1 5
4	4	4
3 5 1	5 1 3	5 3 1
4	4	4
1 3 4	1 4 3	3 1 4
5	5	5

3	4	1	4	1	3	4	3	1
	5			5			5	

3.8. $R = (1, 3, 4, 6)$

3	4	6	3	6	4	4	3	6
	1			1			1	

4	6	3	6	3	4	6	4	3
	1			1			1	

1	4	6	1	6	4	4	1	6
	3			3			3	

4	6	1	6	1	4	6	4	1
	3			3			3	

1	3	6	1	6	3	3	1	6
	4			4			4	

3	6	1	6	1	3	6	3	1
	4			4			4	

1	3	4	1	4	3	3	1	4
	6			6			6	

3	4	1	4	1	3	4	3	1
	6			6			6	

3.9. $R = (1, 3, 5, 6)$

3	5	6	3	6	5	5	3	6
	1			1			1	

5	6	3	6	3	5	6	5	3
---	---	---	---	---	---	---	---	---

	1			1			1	
1	5	6		1	6	5	5	1
	3				3			3
5	6	1		6	1	5	6	5
	3				3			3
1	3	6		1	6	3	3	1
	5				5			5
3	6	1		6	1	3	6	3
	5				5			5
1	3	5		1	5	3	3	1
	6				6			6
3	5	1		5	1	3	5	3
	6				6			6

3.10. $R = (1, 4, 5, 6)$

4	5	6		4	6	5	5	4
	1				1			1
5	6	4		6	4	5	6	5
	1				1			1
1	5	6		1	6	5	5	1
	4				4			4
5	6	1		6	1	5	6	5
	4				4			4
1	4	6		1	6	4	4	1
	5				5			5
4	6	1		6	1	4	6	4
	5				5			5

1	4	5	1	5	4	4	1	5
	6			6			6	
4	5	1	5	1	4	5	4	1
	6			6			6	

3.11. $R = (2, 3, 4, 5)$

3	4	5	3	5	4	4	3	5
	2			2			2	
4	5	3	5	3	4	5	4	3
	2			2			2	
2	4	5	2	5	4	4	2	5
	3			3			3	
4	5	2	5	2	4	5	4	2
	3			3			3	
2	3	5	2	5	3	3	2	5
	4			4			4	
3	5	2	5	2	3	5	3	2
	4			4			4	
2	3	4	2	4	3	3	2	4
	5			5			5	
3	4	2	4	2	3	4	3	2
	5			5			5	

3.12. $R = (2, 3, 4, 6)$

3	4	6	3	6	4	4	3	6
---	---	---	---	---	---	---	---	---

	2			2			2		
4	6	3		6	3	4	6	4	3
	2				2			2	
2	4	6		2	6	4	4	2	6
	3				3			3	
4	6	2		6	2	4	6	4	2
	3				3			3	
2	3	6		2	6	3	3	2	6
	4				4			4	
3	6	2		6	2	3	6	3	2
	4				4			4	
2	3	4		2	4	3	3	2	4
	6				6			6	
3	4	2		4	2	3	4	3	2
	6				6			6	

3.13. $R = (2, 3, 5, 6)$

3	5	6		3	6	5		5	3	6
	2				2				2	
5	6	3		6	3	5		6	5	3
	2				2				2	
2	5	6		2	6	5		5	2	6
	3				3				3	
5	6	2		6	2	5		6	5	2
	3				3				3	

2	3	6	2	6	3	3	2	6
	5			5			5	
3	6	2	6	2	3	6	3	2
	5			5			5	
2	3	5	2	5	3	3	2	5
	6			6			6	
3	5	2	5	2	3	5	3	2
	6			6			6	

3.14. $R = (2, 4, 5, 6)$

4	5	6	4	6	5	5	4	6
	2			2			2	
5	6	4	6	4	5	6	5	4
	2			2			2	
2	5	6	2	6	5	5	2	6
	4			4			4	
5	6	2	6	2	5	6	5	2
	4			4			4	
2	4	6	2	6	4	4	2	6
	5			5			5	
4	6	2	6	2	4	6	4	2
	5			5			5	
2	4	5	2	5	4	4	2	5
	6			6			6	
4	5	2	5	2	4	5	4	2
	6			6			6	

3.15. $R = (3, 4, 5, 6)$

4	5	6	4	6	5	5	4	6
	3			3			3	
5	6	4	6	4	5	6	5	4
	3			3			3	
3	5	6	3	6	5	5	3	6
	4			4			4	
5	6	3	6	3	5	6	5	3
	4			4			4	
3	4	6	3	6	4	4	3	6
	5			5			6	
4	6	3	6	3	4	6	4	3
	5			5			5	
3	4	5	3	5	4	4	3	5
	6			6			6	
4	5	3	5	3	4	5	4	3
	6			6			6	

Literatur

- Bense, Max, Semiotische Prozesse und Systeme. Baden-Baden 1975
- Bense, Max, Die Unwahrscheinlichkeit des Ästhetischen. Baden-Baden 1979
- Bense, Max, Axiomatik und Semiotik. Baden-Baden 1981
- Gardner, Martin, Mathematical Games: The fantastic combinations of John Conway's new solitaire game "Life". In: Scientific American, vol. 223 (Oct. 1970), S. 120–123
- Kaehr, Rudolf, Kähr's Catalog of morphic CA-Patterns. Part V: Examples of rule-CIR and RCI. Glasgow 2015. Digitalisat:
http://www.vordenker.de/rk/rk_Kahrs-Catalog-of-morphic-CA-patterns_Part-V_2015.pdf (2015a)

- Kaehr, Rudolf, Metaphors of Dissemination and Interaction of MorphoCAs. Glasgow 2015. Digitalisat: [www.vordenker.de/rk/rk Metaphors-of-Dissemination-and-Interaction-of-morphoCAs Diagrams 2015.pdf](http://www.vordenker.de/rk/rk%20Metaphors-of-Dissemination-and-Interaction-of-morphoCAs%20Diagrams%202015.pdf) (2015b)
- Klaus, Georg, Semiotik. Berlin (DDR) 1962, 4. Aufl. München 1973
- Toth, Alfred, Kontexturen statt Trichotomien. In: Electronic Journal for Mathematical Semiotics, 2019a
- Toth, Alfred, Grundlegung einer polykontexturalen Semiotik. Tucson, AZ, 2019 (= 2019b)
- von Neumann, John/A.W. Burks, Theory of Self-Reproducing Automata. Urbana, IL, 1966
- Walther, Elisabeth, Allgemeine Zeichenlehre. 2. Aufl. Stuttgart 1979

Die Autoreproduktion von Subzeichen in semiotischen Automaten

1. Im folgenden werden die Ergebnisse von Toth (2019) vorausgesetzt.

2. Zelluläre Automaten sind eine Form von autoreproduktiven Automaten (vgl. von Neumann 1966), die zuerst von John H. Conway entdeckt wurden (vgl. Gardner 1970). Ein CA (cellular automata) ist ein Pattern aus 4 Plätzen, die belegt („lebendig“) oder unbelegt („tot“) sein können. CAs werden durch $2^8 = 256$ Regeln bestimmt, durch deren fortgesetzte Anwendung fraktalartige Gebilde entstehen; vgl. als Beispiel den CA der Regel 30.

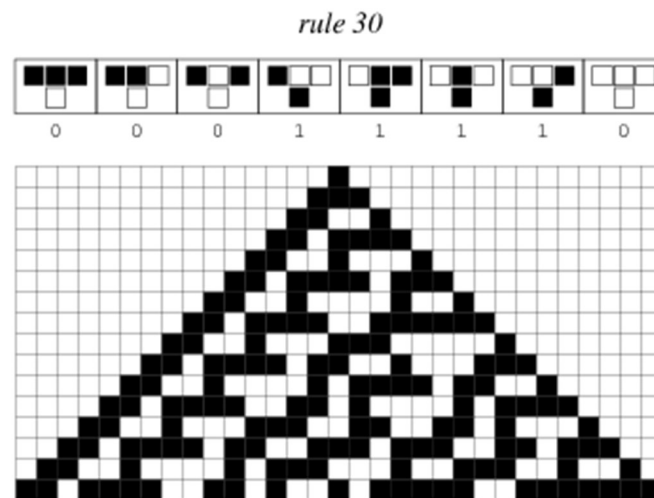

Eine besondere Schwierigkeit bestand darin, CAs für die 15 Basis-Morphogramme der Güntherlogik zu konstruieren. Nach Kaehr (2015a, S. 5) sind die CAs der Morphogramme in Intra-, Trans-, Inter- und mediative CAs differenzierbar.

3. Eine besondere Stellung innerhalb der qualitativ-mathematischen CAs nehmen die semiotischen ein, und hier stellen sich noch viel beträchtlichere Schwierigkeiten, denn bei semiotischen CAs gibt es keine unbelegten Zellen. Legt man $Z_{2,3}$ zugrunde, dann sind 6 Elemente (Subzeichen) auf 4 Plätze zu verteilen. Man erhält also $\binom{6}{4} = (720 : 2) = 360$ polykontexturale semiotische CAs, die im folgenden durch die Subzeichen (z) von $Z_{2,3}$ statt durch Farben dargestellt werden. Die 360 semio-CAs sind nach Gruppen von Mengen von $z \in Z_{2,3}$ geordnet, welche als Input für einen semiotischen CA und dessen Permutationen verwendet werden.

3.1. $R = ((1.1), (1.2), (1.3), (2.1))$

(1.2) (1.3) (2.1) (1.1)	(1.2) (2.1) (1.3) (1.1)	(1.3) (1.2) (2.1) (1.1)
(1.3) (2.1) (1.2) (1.1)	(2.1) (1.2) (1.3) (1.1)	(2.1) (1.3) (1.2) (1.1)
(1.1) (1.3) (2.1) (1.2)	(1.1) (2.1) (1.3) (1.2)	(1.3) (1.1) (2.1) (1.2)
(1.3) (2.1) (1.1) (1.2)	(2.1) (1.1) (1.3) (1.2)	(2.1) (1.3) (1.1) (1.2)
(1.1) (1.2) (2.1) (1.3)	(1.1) (2.1) (1.2) (1.3)	(1.2) (1.1) (2.1) (1.3)
(1.2) (2.1) (1.1) (1.3)	(2.1) (1.1) (1.2) (1.3)	(2.1) (1.2) (1.1) (1.3)
(1.1) (1.2) (1.3) (2.1)	(1.1) (1.3) (1.2) (2.1)	(1.2) (1.1) (1.3) (2.1)
(1.2) (1.3) (1.1) (2.1)	(1.3) (1.1) (1.2) (2.1)	(1.3) (1.2) (1.1) (2.1)

3.2. $R = ((1.1), (1.2), (1.3), (2.2))$

(1.2) (1.3) (2.2) (1.1)	(1.2) (2.2) (1.3) (1.1)	(1.3) (1.2) (2.2) (1.1)
(1.3) (2.2) (1.2) (1.1)	(2.2) (1.2) (1.3) (1.1)	(2.2) (1.3) (1.2) (1.1)
(1.1) (1.3) (2.2) (1.2)	(1.1) (2.2) (1.3) (1.2)	(1.3) (1.1) (2.2) (1.2)

(2.3)

(2.3)

(2.3)

3.4. R = ((1.1), (1.2), (2.1), (2.2))

(1.2) (2.1) (2.2)
(1.1)

(1.2) (2.2) (2.1)
(1.1)

(2.1) (1.2) (2.2)
(1.1)

(2.1) (2.2) (1.2)
(1.1)

(2.2) (1.2) (2.1)
(1.1)

(2.2) (2.1) (1.2)
(1.1)

(1.1) (2.1) (2.2)
(1.2)

(1.1) (2.2) (2.1)
(1.2)

(2.1) (1.1) (2.2)
(1.2)

(2.1) (2.2) (1.1)
(1.2)

(2.2) (1.1) (2.1)
(1.2)

(2.2) (2.1) (1.1)
(1.2)

(1.1) (1.2) (2.2)
(2.1)

(1.1) (2.2) (1.2)
(2.1)

(1.2) (1.1) (2.2)
(2.1)

(1.2) (2.2) (1.1)
(2.1)

(2.2) (1.1) (1.2)
(2.1)

(2.2) (1.2) (1.1)
(2.1)

(1.1) (1.2) (2.1)
(2.2)

(1.1) (2.1) (1.2)
(2.2)

(1.2) (1.1) (2.1)
(2.2)

(1.2) (2.1) (1.1)
(2.2)

(2.1) (1.1) (1.2)
(2.2)

(2.1) (1.2) (1.1)
(2.2)

3.5. R = ((1.1), (1.2), (2.1), (2.3))

(1.2) (2.1) (2.3)
(1.1)

(1.2) (2.3) (2.1)
(1.1)

(2.1) (1.2) (2.3)
(1.1)

(2.1) (2.3) (1.2)
(1.1)

(2.3) (1.2) (2.1)
(1.1)

(2.3) (2.1) (1.2)
(1.1)

(1.1) (2.1) (2.3)

(1.1) (2.3) (2.1)

(2.1) (1.1) (2.3)

(1.2)	(1.2)	(1.2)
(2.1) (2.3) (1.1) (1.2)	(2.3) (1.1) (2.1) (1.2)	(2.3) (2.1) (1.1) (1.2)
(1.1) (1.2) (2.3) (2.1)	(1.1) (2.3) (1.2) (2.1)	(1.2) (1.1) (2.3) (2.1)
(1.2) (2.3) (1.1) (2.1)	(2.3) (1.1) (1.2) (2.1)	(2.3) (1.2) (1.1) (1.3)
(1.1) (1.2) (2.1) (2.3)	(1.1) (2.1) (1.2) (2.3)	(1.2) (1.1) (2.1) (2.3)
(1.2) (2.1) (1.1) (2.3)	(2.1) (1.1) (1.2) (2.3)	(2.1) (1.2) (1.1) (2.3)

3.6. $R = ((1.1), (1.2), (2.2), (2.3))$

(1.2) (2.2) (2.3) (1.1)	(1.2) (2.3) (2.2) (1.1)	(2.2) (1.2) (2.3) (1.1)
(2.2) (2.3) (1.2) (1.1)	(2.3) (1.2) (2.2) (1.1)	(2.3) (2.2) (1.2) (1.1)
(1.1) (2.2) (2.3) (1.2)	(1.1) (2.3) (2.2) (1.2)	(2.2) (1.1) (2.3) (1.2)
(2.2) (2.3) (1.1) (1.2)	(2.3) (1.1) (2.2) (1.2)	(2.3) (2.2) (1.1) (1.2)
(1.1) (1.2) (2.3) (2.2)	(1.1) (2.3) (1.2) (2.2)	(1.2) (1.1) (2.3) (2.2)
(1.2) (2.3) (1.1) (2.2)	(2.3) (1.1) (1.2) (2.2)	(2.3) (1.2) (1.1) (2.3)
(1.1) (1.2) (2.2)	(1.1) (2.2) (1.2)	(1.2) (1.1) (2.2)

(2.3)	(2.3)	(2.3)
(1.2) (2.2) (1.1) (2.3)	(2.2) (1.1) (1.2) (2.3)	(2.2) (1.2) (1.1) (2.3)

3.7. $R = ((1.1), (1.3), (2.1), (2.2))$

(1.3) (2.1) (2.2) (1.1)	(1.3) (2.2) (2.1) (1.1)	(2.1) (1.3) (2.2) (1.1)
(2.1) (2.2) (1.3) (1.1)	(2.2) (1.3) (2.1) (1.1)	(2.2) (2.1) (1.3) (1.1)
(1.1) (2.1) (2.2) (1.3)	(1.1) (2.2) (2.1) (1.3)	(2.1) (1.1) (2.2) (1.3)
(2.1) (2.2) (1.1) (1.3)	(2.2) (1.1) (2.1) (1.3)	(2.2) (2.1) (1.1) (1.3)
(1.1) (1.3) (2.2) (2.1)	(1.1) (2.2) (1.3) (2.1)	(1.3) (1.1) (2.2) (2.1)
(1.3) (2.2) (1.1) (2.1)	(2.2) (1.1) (1.3) (2.1)	(2.2) (1.3) (1.1) (2.1)
(1.1) (1.3) (2.1) (2.2)	(1.1) (2.1) (1.3) (2.2)	(1.3) (1.1) (2.1) (2.2)
(1.3) (2.1) (1.1) (2.2)	(2.1) (1.1) (1.3) (2.2)	(2.1) (1.3) (1.1) (2.2)

3.8. $R = ((1.1), (1.3), (2.1), (2.3))$

(1.3) (2.1) (2.3) (1.1)	(1.3) (2.3) (2.1) (1.1)	(2.1) (1.3) (2.3) (1.1)
(2.1) (2.3) (1.3) (1.1)	(2.3) (1.3) (2.1) (1.1)	(2.3) (2.1) (1.3) (1.1)

(1.1) (2.1) (2.3) (1.3)	(1.1) (2.3) (2.1) (1.3)	(2.1) (1.1) (2.3) (1.3)
(2.1) (2.3) (1.1) (1.3)	(2.3) (1.1) (2.1) (1.3)	(2.3) (2.1) (1.1) (1.3)
(1.1) (1.3) (2.3) (2.1)	(1.1) (2.3) (1.3) (2.1)	(1.3) (1.1) (2.3) (2.1)
(1.3) (2.3) (1.1) (2.1)	(2.3) (1.1) (1.3) (2.1)	(2.3) (1.3) (1.1) (2.1)
(1.1) (1.3) (2.1) (2.3)	(1.1) (2.1) (1.3) (2.3)	(1.3) (1.1) (2.1) (2.3)
(1.3) (2.1) (1.1) (2.3)	(2.1) (1.1) (1.3) (2.3)	(2.1) (1.3) (1.1) (2.3)

3.9. $R = ((1.1), (1.3), (2.2), (2.3))$

(1.3) (2.2) (2.3) (1.1)	(1.3) (2.3) (2.2) (1.1)	(2.2) (1.3) (2.3) (1.1)
(2.2) (2.3) (1.3) (1.1)	(2.3) (1.3) (2.2) (1.1)	(2.3) (2.2) (1.3) (1.1)
(1.1) (2.2) (2.3) (1.3)	(1.1) (2.3) (2.2) (1.3)	(2.2) (1.1) (2.3) (1.3)
(2.2) (2.3) (1.1) (1.3)	(2.3) (1.1) (2.2) (1.3)	(2.3) (2.2) (1.1) (1.3)
(1.1) (1.3) (2.3) (2.2)	(1.1) (2.3) (1.3) (2.2)	(1.3) (1.1) (2.3) (2.2)
(1.3) (2.3) (1.1) (2.2)	(2.3) (1.1) (1.3) (2.2)	(2.3) (1.3) (1.1) (2.2)

(1.1) (1.3) (2.2) (1.1) (2.2) (1.3) (1.3) (1.1) (2.2)
(2.3) (2.3) (2.3)

(1.3) (2.2) (1.1) (2.2) (1.1) (1.3) (2.2) (1.3) (1.1)
(2.3) (2.3) (2.3)

3.10. $R = ((1.1), (2.1), (2.2), (2.3))$

(2.1) (2.2) (2.3) (2.1) (2.3) (2.2) (2.2) (2.1) (2.3)
(1.1) (1.1) (1.1)

(2.2) (2.3) (2.1) (2.3) (2.1) (2.2) (2.3) (2.2) (2.1)
(1.1) (1.1) (1.1)

(1.1) (2.2) (2.3) (1.1) (2.3) (2.2) (2.2) (1.1) (2.3)
(2.1) (2.1) (2.1)

(2.2) (2.3) (1.1) (2.3) (1.1) (2.2) (2.3) (2.2) (1.1)
(2.1) (2.1) (2.1)

(1.1) (2.1) (2.3) (1.1) (2.3) (2.1) (2.1) (1.1) (2.3)
(2.2) (2.2) (2.2)

(2.1) (2.3) (1.1) (2.3) (1.1) (2.1) (2.3) (2.1) (1.1)
(2.2) (2.2) (2.2)

(1.1) (2.1) (2.2) (1.1) (2.2) (2.1) (2.1) (1.1) (2.2)
(2.3) (2.3) (2.3)

(2.1) (2.2) (1.1) (2.2) (1.1) (2.1) (2.2) (2.1) (1.1)
(2.3) (2.3) (2.3)

3.11. $R = ((1.2), (1.3), (2.1), (2.2))$

(1.3) (2.1) (2.2) (1.3) (2.2) (2.1) (2.1) (1.3) (2.2)
(1.2) (1.2) (1.2)

(1.2)	(1.2)	(1.2)
(2.2) (2.3) (2.1) (1.2)	(2.3) (2.1) (2.2) (1.2)	(2.3) (2.2) (2.1) (1.2)
(1.2) (2.2) (2.3) (2.1)	(1.2) (2.3) (2.2) (2.1)	(2.2) (1.2) (2.3) (2.1)
(2.2) (2.3) (1.2) (2.1)	(2.3) (1.2) (2.2) (2.1)	(2.3) (2.2) (1.2) (2.1)
(1.2) (2.1) (2.3) (2.2)	(1.2) (2.3) (2.1) (2.2)	(2.1) (1.2) (2.3) (2.2)
(2.1) (2.3) (1.2) (2.2)	(2.3) (1.2) (2.1) (2.2)	(2.3) (2.1) (1.2) (2.2)
(1.2) (2.1) (2.2) (2.3)	(1.2) (2.2) (2.1) (2.3)	(2.1) (1.2) (2.2) (2.3)
(2.1) (2.2) (1.2) (2.3)	(2.2) (1.2) (2.1) (2.3)	(2.2) (2.1) (1.2) (2.3)

3.15. $R = ((1.3), (2.1), (2.2), (2.3))$

(2.1) (2.2) (2.3) (1.3)	(2.1) (2.3) (2.2) (1.3)	(2.2) (2.1) (2.3) (1.3)
(2.2) (2.3) (2.1) (1.3)	(2.3) (2.1) (2.2) (1.3)	(2.3) (2.2) (2.1) (1.3)
(1.3) (2.2) (2.3) (2.1)	(1.3) (2.3) (2.2) (2.1)	(2.2) (1.3) (2.3) (2.1)
(2.2) (2.3) (1.3) (2.1)	(2.3) (1.3) (2.2) (2.1)	(2.3) (2.2) (1.3) (2.1)

(1.3) (2.1) (2.3) (2.2)	(1.3) (2.3) (2.1) (2.2)	(2.1) (1.3) (2.3) (2.3)
(2.1) (2.3) (1.3) (2.2)	(2.3) (1.3) (2.1) (2.2)	(2.3) (2.1) (1.3) (2.2)
(1.3) (2.1) (2.2) (2.3)	(1.3) (2.2) (2.1) (2.3)	(2.1) (1.3) (2.2) (2.3)
(2.1) (2.2) (1.3) (2.3)	(2.2) (1.3) (2.1) (2.3)	(2.2) (2.1) (1.3) (2.3)

Literatur

- Gardner, Martin, Mathematical Games: The fantastic combinations of John Conway's new solitaire game "Life". In: Scientific American, vol. 223 (Oct. 1970), S. 120–123
- Kaehr, Rudolf, Kähr's Catalog of morphic CA-Patterns. Part V: Examples of rule-CIR and RCI. Glasgow 2015. Digitalisat: http://www.vordenker.de/rk/rk_Kahrs-Catalog-of-morphic-CA-patterns_Part-V_2015.pdf (2015a)
- Kaehr, Rudolf, Metaphors of Dissemination and Interaction of MorphoCAs. Glasgow 2015. Digitalisat: www.vordenker.de/rk/rk_Metaphors-of-Dissemination-and-Interaction-of-morphoCAs_Diagrams_2015.pdf (2015b)
- Toth, Alfred, Polykontexturale semiotische Automaten. In: Electronic Journal for Mathematical Semiotics, 2019
- von Neumann, John/A.W. Burks, Theory of Self-Reproducing Automata. Urbana, IL, 1966

Die Autoreproduktion von Proto- und Deuterозahlen in semiotischen Automaten

1. Im folgenden werden die Ergebnisse von Toth (2019a, b) vorausgesetzt.
2. Zelluläre Automaten sind eine Form von autoreproduktiven Automaten (vgl. von Neumann 1966), die zuerst von John H. Conway entdeckt wurden (vgl. Gardner 1970). Ein CA (cellular automata) ist ein Pattern aus 4 Plätzen, die belegt („lebendig“) oder unbelegt („tot“) sein können. CAs werden durch $2^8 = 256$ Regeln bestimmt, durch deren fortgesetzte Anwendung fraktalartige Gebilde entstehen; vgl. als Beispiel den CA der Regel 30.

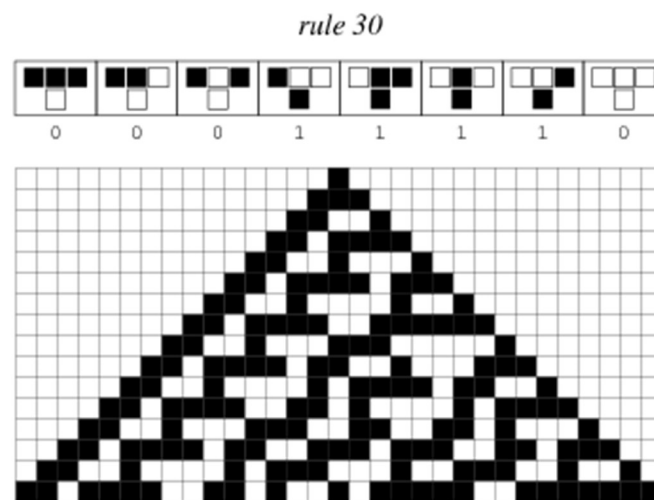

Eine besondere Schwierigkeit bestand darin, CAs für die 15 Basis-Morphogramme der Güntherlogik zu konstruieren. Nach Kaehr (2015a, S. 5) sind die CAs der Morphogramme in Intra-, Trans-, Inter- und mediative CAs differenzierbar.

3. Eine besondere Stellung innerhalb der qualitativ-mathematischen CAs nehmen die semiotischen ein, und hier stellen sich noch viel beträchtlichere Schwierigkeiten, denn bei semiotischen CAs gibt es keine unbelegten Zellen. Legt man $Z_{2,3}$ zugrunde, dann sind 6 Elemente (Subzeichen) auf 4 Plätze zu verteilen. Man erhält also $\binom{6}{4} = (720 : 2) = 360$ polykontexturale semiotische CAs, die im folgenden durch die Proto- = Deuterозahlen von $K = 1$ bis $K = 3$ von $Z_{2,3}$ (vgl. Toth 2019c) statt durch Farben dargestellt werden. Die 360 semio-CAs sind nach Gruppen von Mengen von $z \in Z_{2,3}$ geordnet, welche als Input für einen semiotischen CA und dessen Permutationen verwendet werden.

3.1. $R = (0, 00, 01, 000)$

00	01	000	00	000	01	01	00	000
	0			0			0	
01	000	00	000	00	01	000	01	00
	0			0			0	
0	01	000	0	000	01	01	0	000
	00			00			00	
01	000	0	000	0	01	000	01	0
	00			00			00	
0	00	000	0	000	00	00	0	000
	01			01			01	
00	000	0	000	0	00	000	00	0
	01			01			01	
0	00	01	0	01	00	00	0	01
	000			000			000	
00	01	0	01	0	00	01	00	0
	000			000			000	

3.2. $R = (0, 00, 01, 001)$

00	01	001	00	001	01	01	00	001
	0			0			0	
01	001	00	001	00	01	001	01	00
	0			0			0	
0	01	001	0	001	01	01	0	001
	00			00			00	

01	001	0	001	0	01	001	01	0
	00			00			00	
0	00	001	0	001	00	00	0	001
	01			01			01	
00	001	0	001	0	00	001	00	0
	01			01			01	
0	00	01	0	01	00	00	0	01
	001			001			001	
00	01	0	01	0	00	01	00	0
	001			001			001	

3.3. $R = (0, 00, 01, 012)$

00	01	012	00	012	01	01	00	012
	0			0			0	
01	012	00	012	00	01	012	01	00
	0			0			0	
0	01	012	0	012	01	01	0	012
	00			00			00	
01	012	0	012	0	01	012	01	0
	00			00			00	
0	00	012	0	012	00	00	0	012
	01			01			01	
00	012	0	012	0	00	012	00	0
	01			01			01	
0	00	01	0	01	00	00	0	01
	012			012			012	
00	01	0	01	0	00	01	00	0

012

012

012

3.4. R = (0, 00, 000, 001)

00	000	001	00	001	000	000	00	001
	0			0			0	
000	001	00	001	00	000	001	000	00
	0			0			0	
0	000	001	0	001	000	000	0	001
	00			00			00	
000	001	0	001	0	000	001	000	0
	00			00			00	
0	00	001	0	001	00	00	0	001
	000			000			000	
00	001	0	001	0	00	001	00	0
	000			000			000	
0	00	000	0	000	00	00	0	000
	001			001			001	
00	000	0	000	0	00	000	00	0
	001			001			001	

3.5. R = (0, 00, 000, 012)

00	000	012	00	012	000	000	00	012
	0			0			0	
000	012	00	012	00	000	012	000	00
	0			0			0	
0	000	012	0	012	000	000	0	012

	00			00			00	
000	012	0		012	0	000	012	000
	00			00			00	
0	00	012		0	012	00	00	0
	000			000			000	
00	012	0		012	0	00	012	00
	000			000			01	
0	00	000		0	000	00	00	0
	012			012			012	000
00	000	0		000	0	00	000	00
	012			012			012	

3.6. $R = (0, 00, 001, 012)$

00	001	012		00	012	001	001	00	012
	0				0			0	
001	012	00		012	00	001	012	001	00
	0				0			0	
0	001	012		0	012	001	001	0	012
	00				00			00	
001	012	0		012	0	001	012	001	0
	00				00			00	
0	00	012		0	012	00	00	0	012
	001				001			001	
00	012	0		012	0	00	012	00	0
	001				001			012	
0	00	001		0	001	00	00	0	001
	012				012			012	

00	001	0	001	0	00	001	00	0
	012			012			012	

3.7. $R = (0, 01, 000, 001)$

01	000	001	01	001	000	000	01	001
	0			0			0	

000	001	01	001	01	000	001	000	01
	0			0			0	

0	000	001	0	001	000	000	0	001
	01			01			01	

000	001	0	001	0	000	001	000	0
	01			01			01	

0	01	001	0	001	01	01	0	001
	000			000			000	

01	001	0	001	0	01	001	01	0
	000			000			000	

0	01	000	0	000	01	01	0	000
	001			001			001	

01	000	0	000	0	01	000	01	0
	001			001			001	

3.8. $R = (0, 01, 000, 012)$

01	000	012	01	012	000	000	01	012
	0			0			0	

000	012	01	012	01	000	012	000	01
-----	-----	----	-----	----	-----	-----	-----	----

	0			0			0	
0	000	012		0	012	000	000	0 012
	01			01			01	
000	012	0		012	0	000	012	000 0
	01			01			01	
0	01	012		0	012	01	01	0 012
	000			000			000	
01	012	0		012	0	01	012	01 0
	000			000			000	
0	01	000		0	000	01	01	0 000
	012			012			012	
01	000	0		000	0	01	000	01 0
	012			012			012	

3.9. $R = (0, 01, 001, 012)$

01	001	012		01	012	001	001	01 012
	0			0			0	
001	012	01		012	01	001	012	001 01
	0			0			0	
0	001	012		0	012	001	001	0 012
	01			01			01	
001	012	0		012	0	001	012	001 0
	01			01			01	
0	01	012		0	012	01	01	0 012
	001			001			001	
01	012	0		012	0	01	012	01 0
	001			001			001	

0	01	001	0	001	01	01	0	001
	012			012			012	

01	001	0	001	0	01	001	01	0
	012			012			012	

3.10. $R = (0, 000, 001, 012)$

000	001	012	000	012	001	001	000	012
	0			0			0	

001	012	000	012	000	001	012	001	000
	0			0			0	

0	001	012	0	012	001	001	0	012
	000			000			000	

001	012	0	012	0	001	012	001	0
	000			000			000	

0	000	012	0	012	000	000	0	012
	001			001			001	

000	012	0	012	0	000	012	000	0
	001			001			001	

0	000	001	0	001	000	000	0	001
	012			012			012	

000	001	0	001	0	000	001	000	0
	012			012			012	

3.11. $R = (00, 01, 000, 001)$

01	000	001	01	001	000	000	01	001
----	-----	-----	----	-----	-----	-----	----	-----

	00			00			00		
000	001	01		001	01	000	001	000	01
	00				00			00	
00	000	001		00	001	000	000	00	001
	01				01			01	
000	001	00		001	00	000	001	000	00
	01				01			01	
00	01	001		00	001	01	01	00	001
	000				000			000	
01	001	00		001	00	01	001	01	00
	000				000			000	
00	01	000		00	000	01	01	00	000
	001				001			001	
01	000	00		000	00	01	000	01	00
	001				001			001	

3.12. $R = (00, 01, 000, 012)$

01	000	012		01	012	000		000	01	012
	00				00				00	
000	012	01		012	01	000		012	000	01
	00				00				00	
00	000	012		00	012	000		000	00	012
	01				01				01	
000	012	00		012	00	000		012	000	00
	01				01				01	

00	01	012	00	012	01	01	00	012
	000			000			000	
01	012	00	012	00	01	012	01	00
	000			000			000	
00	01	000	00	000	01	01	00	000
	012			012			012	
01	000	00	000	00	01	000	01	00
	012			012			012	

3.13. $R = (00, 01, 001, 012)$

01	001	012	01	012	001	001	01	012
	00			00			00	
001	012	01	012	01	001	012	001	01
	00			00			00	
00	001	012	00	012	001	001	00	012
	01			01			01	
001	012	00	012	00	001	012	001	00
	01			01			01	
00	01	012	00	012	01	01	00	012
	001			001			001	
01	012	00	012	00	01	012	01	00
	001			001			001	
00	01	001	00	001	01	01	00	001
	012			012			012	
01	001	00	001	00	01	001	01	00
	012			012			012	

3.14. $R = (00, 000, 001, 012)$

000	001	012	000	012	001	001	000	012
	00			00			00	
001	012	000	012	000	001	012	001	000
	00			00			00	
00	001	012	00	012	001	001	00	012
	000			000			000	
001	012	00	012	00	001	012	001	00
	000			000			000	
00	000	012	00	012	000	000	00	012
	001			001			001	
000	012	00	012	00	000	012	000	00
	001			001			001	
00	000	001	00	001	000	000	00	001
	012			012			012	
000	001	00	001	00	000	001	000	00
	012			012			012	

3.15. $R = (01, 000, 001, 012)$

000	001	012	000	012	001	001	000	012
	01			01			01	
001	012	000	012	000	001	012	001	000
	01			01			01	
01	001	012	01	012	001	001	01	012
	000			000			000	
001	012	01	012	01	001	012	001	01

	000		000		000
01	000 012		01 012 000		000 01 012
	001		001		012
000	012 01		012 01 000		012 000 01
	001		001		001
01	000 001		01 001 000		000 01 001
	012		012		012
000	001 01		001 01 000		001 000 01
	012		012		012

Literatur

- Gardner, Martin, Mathematical Games: The fantastic combinations of John Conway's new solitaire game "Life". In: Scientific American, vol. 223 (Oct. 1970), S. 120–123
- Kaehr, Rudolf, Kähr's Catalog of morphic CA-Patterns. Part V: Examples of rule-CIR and RCI. Glasgow 2015. Digitalisat: http://www.vordenker.de/rk/rk_Kahrs-Catalog-of-morphic-CA-patterns_Part-V_2015.pdf (2015a)
- Kaehr, Rudolf, Metaphors of Dissemination and Interaction of MorphoCAs. Glasgow 2015. Digitalisat: www.vordenker.de/rk/rk_Metaphors-of-Dissemination-and-Interaction-of-morphoCAs_Diagrams_2015.pdf (2015b)
- Toth, Alfred, Polykontexturale semiotische Automaten. In: Electronic Journal for Mathematical Semiotics, 2019a
- Toth, Alfred, Die Autoreproduktion von Subzeichen in semiotischen Automaten. In: Electronic Journal for Mathematical Semiotics, 2019b
- Toth, Alfred, Grundlegung einer polykontexturalen Semiotik. Tucson, AZ, 2019 (= 2019c)
- von Neumann, John/A.W. Burks, Theory of Self-Reproducing Automata. Urbana, IL, 1966

Kategorientheoretische Darstellung polykontextualer semiotischer Automaten

1. Im folgenden werden die Ergebnisse von Toth (2019a-d) vorausgesetzt.

2. Zelluläre Automaten sind eine Form von autoreproduktiven Automaten (vgl. von Neumann 1966), die zuerst von John H. Conway entdeckt wurden (vgl. Gardner 1970). Ein CA (cellular automata) ist ein Pattern aus 4 Plätzen, die belegt („lebendig“) oder unbelegt („tot“) sein können. CAs werden durch $2^8 = 256$ Regeln bestimmt, durch deren fortgesetzte Anwendung fraktalartige Gebilde entstehen; vgl. als Beispiel den CA der Regel 30.

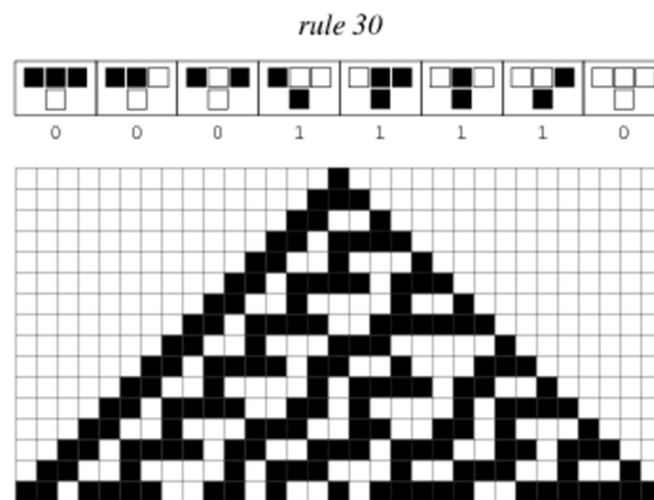

Eine besondere Schwierigkeit bestand darin, CAs für die 15 Basis-Morphogramme der Güntherlogik zu konstruieren. Nach Kaehr (2015, S. 5) sind die CAs der Morphogramme in Intra-, Trans-, Inter- und mediative CAs differenzierbar.

3. Eine besondere Stellung innerhalb der qualitativ-mathematischen CAs nehmen die semiotischen ein, und hier stellen sich noch viel beträchtlichere Schwierigkeiten, denn bei semiotischen CAs gibt es keine unbelegten Zellen. Legt man $Z_{2,3}$ zugrunde, dann sind 6 Elemente (Subzeichen) auf 4 Plätze zu verteilen. Man erhält also $\binom{6}{4} = (720 : 2) = 360$ polykontexturale semiotische CAs, die im folgenden durch die Proto- = Deuterzahlen von $K = 1$ bis $K = 3$ von $Z_{2,3}$ (vgl. Toth 2019e) statt durch Farben dargestellt werden. Die 360 semio-CAs sind nach Gruppen von Mengen von $z \in Z_{2,3}$ geordnet, welche als Input für einen semiotischen CA und dessen Permutationen verwendet werden. Für die folgende Darstellung wurden zusätzlich die in Toth (2019d) definierten Morphismen verwendet. Damit können semiotische CAs erstmals

unabhängig von diamonds (welche kontexturierte Subzeichen voraussetzen) kategorientheoretisch dargestellt werden.

3.1. R = (0, 00, 01, 000)

$\begin{array}{ccc} 00 & 01 & 000 \\ & 0 & \\ & \downarrow & \\ (\beta \rightarrow \gamma) & \rightarrow & \alpha^\circ \beta^\circ \end{array}$	$\begin{array}{ccc} 00 & 000 & 01 \\ & 0 & \\ & \downarrow & \\ (\gamma\beta \rightarrow \gamma^\circ) & \rightarrow & \alpha^\circ \beta^\circ \gamma^\circ \end{array}$	$\begin{array}{ccc} 01 & 00 & 000 \\ & 0 & \\ & \downarrow & \\ (\beta^\circ \rightarrow \gamma\beta) & \rightarrow & \alpha^\circ \end{array}$
$\begin{array}{ccc} 01 & 000 & 00 \\ & 0 & \\ & \downarrow & \\ (\gamma \rightarrow \beta^\circ \gamma^\circ) & \rightarrow & \alpha^\circ \beta^\circ \gamma^\circ \end{array}$	$\begin{array}{ccc} 000 & 00 & 01 \\ & 0 & \\ & \downarrow & \\ (\beta^\circ \gamma^\circ \rightarrow \beta) & \rightarrow & \alpha^\circ \end{array}$	$\begin{array}{ccc} 000 & 01 & 00 \\ & 0 & \\ & \downarrow & \\ (\gamma^\circ \rightarrow \beta^\circ) & \rightarrow & \alpha^\circ \beta^\circ \end{array}$
$\begin{array}{ccc} 0 & 01 & 000 \\ & 00 & \\ & \downarrow & \\ (\beta\alpha \rightarrow \gamma) & \rightarrow & \beta^\circ \end{array}$	$\begin{array}{ccc} 0 & 000 & 01 \\ & 00 & \\ & \downarrow & \\ (\gamma\beta\alpha \rightarrow \gamma^\circ) & \rightarrow & \beta^\circ \gamma^\circ \end{array}$	$\begin{array}{ccc} 01 & 0 & 000 \\ & 00 & \\ & \downarrow & \\ (\alpha^\circ \beta^\circ \rightarrow \gamma\beta\alpha) & \rightarrow & \alpha \end{array}$
$\begin{array}{ccc} 01 & 000 & 0 \\ & 00 & \\ & \downarrow & \\ (\gamma \rightarrow \alpha^\circ \beta^\circ \gamma^\circ) & \rightarrow & \beta^\circ \gamma^\circ \end{array}$	$\begin{array}{ccc} 000 & 0 & 01 \\ & 00 & \\ & \downarrow & \\ (\alpha^\circ \beta^\circ \gamma^\circ \rightarrow \beta\alpha) & \rightarrow & \alpha \end{array}$	$\begin{array}{ccc} 000 & 01 & 0 \\ & 00 & \\ & \downarrow & \\ (\gamma^\circ \rightarrow \alpha^\circ \beta^\circ) & \rightarrow & \beta^\circ \end{array}$
$\begin{array}{ccc} 0 & 00 & 000 \\ & 01 & \\ & \downarrow & \\ (\alpha \rightarrow \gamma\beta) & \rightarrow & \beta \end{array}$	$\begin{array}{ccc} 0 & 000 & 00 \\ & 01 & \\ & \downarrow & \\ (\gamma\beta\alpha \rightarrow \beta^\circ \gamma^\circ) & \rightarrow & \gamma^\circ \end{array}$	$\begin{array}{ccc} 00 & 0 & 000 \\ & 01 & \\ & \downarrow & \\ (\alpha^\circ \rightarrow \gamma\beta\alpha) & \rightarrow & \beta\alpha \end{array}$
$\begin{array}{ccc} 00 & 000 & 0 \\ & 01 & \\ & \downarrow & \\ (\gamma\beta \rightarrow \alpha^\circ \beta^\circ \gamma^\circ) & \rightarrow & \gamma^\circ \end{array}$	$\begin{array}{ccc} 000 & 0 & 00 \\ & 01 & \\ & \downarrow & \\ (\alpha^\circ \beta^\circ \gamma^\circ \rightarrow \alpha) & \rightarrow & \beta\alpha \end{array}$	$\begin{array}{ccc} 000 & 00 & 0 \\ & 01 & \\ & \downarrow & \\ (\beta^\circ \gamma^\circ \rightarrow \alpha^\circ) & \rightarrow & \beta \end{array}$
$\begin{array}{ccc} 0 & 00 & 01 \end{array}$	$\begin{array}{ccc} 0 & 01 & 00 \end{array}$	$\begin{array}{ccc} 00 & 0 & 01 \end{array}$

000 ↓ $(\alpha \rightarrow \beta) \rightarrow \gamma\beta$	000 ↓ $(\beta\alpha \rightarrow \beta^\circ) \rightarrow \gamma$	000 ↓ $(\alpha^\circ \rightarrow \beta\alpha) \rightarrow \gamma\beta\alpha$
00 01 0 000 ↓ $(\beta \rightarrow \alpha^\circ\beta^\circ) \rightarrow \gamma$	01 0 00 000 ↓ $(\alpha^\circ\beta^\circ \rightarrow \alpha) \rightarrow \gamma\beta\alpha$	01 00 0 000 ↓ $(\beta^\circ \rightarrow \alpha^\circ) \rightarrow \gamma\beta$

3.2. R = (0, 00, 01, 001)

00 01 001 0 ↓ $(\beta \rightarrow \delta\gamma) \rightarrow \alpha^\circ\beta^\circ$	00 001 01 0 ↓ $(\delta\gamma\beta \rightarrow \gamma^\circ\delta^\circ) \rightarrow \alpha^\circ\beta^\circ\gamma^\circ\delta^\circ$	01 00 001 0 ↓ $(\beta^\circ \rightarrow \delta\gamma\beta) \rightarrow \alpha^\circ$
01 001 00 0 ↓ $(\delta\gamma \rightarrow \beta^\circ\gamma^\circ\delta^\circ) \rightarrow \alpha^\circ\beta^\circ\gamma^\circ\delta^\circ$	001 00 01 0 ↓ $(\beta^\circ\gamma^\circ\delta^\circ \rightarrow \beta) \rightarrow \alpha^\circ$	001 01 00 0 ↓ $(\gamma^\circ\delta^\circ \rightarrow \beta^\circ) \rightarrow \alpha^\circ\beta^\circ$
0 01 001 00 ↓ $(\beta\alpha \rightarrow \delta\gamma) \rightarrow \beta^\circ$	0 001 01 00 ↓ $(\delta\gamma\beta\alpha \rightarrow \gamma^\circ\delta^\circ) \rightarrow \beta^\circ\gamma^\circ\delta^\circ$	01 0 001 00 ↓ $(\alpha^\circ\beta^\circ \rightarrow \delta\gamma\beta\alpha) \rightarrow \alpha$
01 001 0 00 ↓ $(\delta\gamma \rightarrow \alpha^\circ\beta^\circ\gamma^\circ\delta^\circ) \rightarrow \beta^\circ\gamma^\circ\delta^\circ$	001 0 01 00 ↓ $(\alpha^\circ\beta^\circ\gamma^\circ\delta^\circ \rightarrow \beta\alpha) \rightarrow \alpha$	001 01 0 00 ↓ $(\gamma^\circ\delta^\circ \rightarrow \alpha^\circ\beta^\circ) \rightarrow \beta^\circ$
0 00 001 01 ↓ $(\alpha \rightarrow \delta\gamma\beta) \rightarrow \beta$	0 001 00 01 ↓ $(\delta\gamma\beta\alpha \rightarrow \beta^\circ\gamma^\circ\alpha^\circ) \rightarrow \gamma^\circ\delta^\circ$	00 0 001 01 ↓ $(\alpha^\circ \rightarrow \delta\gamma\beta\alpha) \rightarrow \beta\alpha$
00 001 0	001 0 00	001 00 0

$$\begin{array}{ccc}
01 & 01 & 01 \\
\downarrow & \downarrow & \downarrow \\
(\delta\gamma\beta \rightarrow \alpha^\circ\beta^\circ\gamma^\circ\delta^\circ) \rightarrow \gamma^\circ\delta^\circ & (\alpha^\circ\beta^\circ\gamma^\circ\delta^\circ \rightarrow \alpha) \rightarrow \beta\alpha & (\beta^\circ\gamma^\circ\alpha^\circ \rightarrow \alpha^\circ) \rightarrow \beta
\end{array}$$

$$\begin{array}{ccc}
0 & 00 & 01 \\
& 001 & \\
\downarrow & & \\
(\alpha \rightarrow \beta) \rightarrow \delta\gamma\beta & (\beta\alpha \rightarrow \beta^\circ) \rightarrow \delta\gamma & (\alpha^\circ \rightarrow \beta\alpha) \rightarrow \delta\gamma\beta\alpha
\end{array}$$

$$\begin{array}{ccc}
00 & 01 & 0 \\
& 001 & \\
\downarrow & & \\
(\beta \rightarrow \alpha^\circ\beta^\circ) \rightarrow \delta\gamma & (\alpha^\circ\beta^\circ \rightarrow \alpha) \rightarrow \delta\gamma\beta\alpha & (\beta^\circ \rightarrow \alpha^\circ) \rightarrow \delta\gamma\beta
\end{array}$$

3.3. R = (0, 00, 01, 012)

$$\begin{array}{ccc}
00 & 01 & 012 \\
& 0 & \\
\downarrow & & \\
(\beta \rightarrow \varepsilon\delta\gamma) \rightarrow \alpha^\circ\beta^\circ & (\varepsilon\delta\gamma\beta \rightarrow \gamma^\circ\delta^\circ\varepsilon^\circ) \rightarrow \alpha^\circ\beta^\circ\gamma^\circ\delta^\circ\varepsilon^\circ & (\beta^\circ \rightarrow \varepsilon\delta\gamma\beta) \rightarrow \alpha^\circ
\end{array}$$

$$\begin{array}{ccc}
01 & 012 & 00 \\
& 0 & \\
\downarrow & & \\
(\varepsilon\delta\gamma \rightarrow \beta^\circ\gamma^\circ\delta^\circ\varepsilon^\circ) \rightarrow \alpha^\circ\beta^\circ\gamma^\circ\delta^\circ\varepsilon^\circ & (\alpha^\circ\beta^\circ\gamma^\circ\delta^\circ\varepsilon^\circ \rightarrow \beta) \rightarrow \alpha^\circ & (\gamma^\circ\delta^\circ\varepsilon^\circ \rightarrow \beta^\circ) \rightarrow \alpha^\circ\beta^\circ
\end{array}$$

$$\begin{array}{ccc}
0 & 01 & 012 \\
& 00 & \\
\downarrow & & \\
(\beta\alpha \rightarrow \varepsilon\delta\gamma) \rightarrow \beta^\circ & (\varepsilon\delta\gamma\beta\alpha \rightarrow \gamma^\circ\delta^\circ\varepsilon^\circ) \rightarrow \beta^\circ\gamma^\circ\delta^\circ\varepsilon^\circ & (\alpha^\circ\beta^\circ \rightarrow \varepsilon\delta\gamma\beta\alpha) \rightarrow \alpha
\end{array}$$

$$\begin{array}{ccc}
01 & 012 & 0 \\
& 00 & \\
\downarrow & & \\
(\varepsilon\delta\gamma \rightarrow \alpha^\circ\beta^\circ\gamma^\circ\delta^\circ\varepsilon^\circ) \rightarrow \beta^\circ\gamma^\circ\delta^\circ\varepsilon^\circ & (\alpha^\circ\beta^\circ\gamma^\circ\delta^\circ\varepsilon^\circ \rightarrow \beta\alpha) \rightarrow \alpha & (\gamma^\circ\delta^\circ\varepsilon^\circ \rightarrow \alpha^\circ\beta^\circ) \rightarrow \beta^\circ
\end{array}$$

$$\begin{array}{ccc}
0 & 00 & 012 \\
& & \\
& &
\end{array}$$

$$\begin{array}{ccc}
01 & 01 & 01 \\
\downarrow & \downarrow & \downarrow \\
(\alpha \rightarrow \varepsilon\delta\gamma\beta) \rightarrow \beta & (\varepsilon\delta\gamma\beta\alpha \rightarrow \beta^\circ\gamma^\circ\delta^\circ\varepsilon^\circ) \rightarrow \gamma^\circ\delta^\circ\varepsilon^\circ & (\alpha^\circ \rightarrow \varepsilon\delta\gamma\alpha) \rightarrow \beta\alpha
\end{array}$$

$$\begin{array}{ccc}
00 & 012 & 0 \\
01 & & \\
\downarrow & & \\
(\varepsilon\delta\gamma\beta \rightarrow \alpha^\circ\beta^\circ\gamma^\circ\delta^\circ\varepsilon^\circ) \rightarrow \gamma^\circ\delta^\circ\varepsilon^\circ & (\alpha^\circ\beta^\circ\gamma^\circ\delta^\circ\varepsilon^\circ \rightarrow \alpha) \rightarrow \beta\alpha & (\beta^\circ\gamma^\circ\delta^\circ\varepsilon^\circ \rightarrow \alpha^\circ) \rightarrow \beta
\end{array}$$

$$\begin{array}{ccc}
0 & 00 & 01 \\
012 & & \\
\downarrow & & \\
(\alpha \rightarrow \beta) \rightarrow \varepsilon\delta\gamma\beta & (\beta\alpha \rightarrow \beta^\circ) \rightarrow \varepsilon\delta\gamma & (\alpha^\circ \rightarrow \beta\alpha) \rightarrow \varepsilon\delta\gamma\beta\alpha
\end{array}$$

$$\begin{array}{ccc}
00 & 01 & 0 \\
012 & & \\
\downarrow & & \\
(\beta \rightarrow \alpha^\circ\beta^\circ) \rightarrow \varepsilon\delta\gamma & (\alpha^\circ\beta^\circ \rightarrow \alpha) \rightarrow \varepsilon\delta\gamma\beta\alpha & (\beta^\circ \rightarrow \alpha^\circ) \rightarrow \varepsilon\delta\gamma\beta
\end{array}$$

3.4. R = (0, 00, 000, 001)

$$\begin{array}{ccc}
00 & 000 & 001 \\
0 & & \\
\downarrow & & \\
(\gamma\beta \rightarrow \delta) \rightarrow \alpha^\circ\beta^\circ\gamma^\circ & (\delta\gamma\beta \rightarrow \delta^\circ) \rightarrow \alpha^\circ\beta^\circ\gamma^\circ\delta^\circ & (\beta^\circ\gamma^\circ \rightarrow \delta\gamma\beta) \rightarrow \alpha^\circ
\end{array}$$

$$\begin{array}{ccc}
000 & 001 & 00 \\
0 & & \\
\downarrow & & \\
(\delta \rightarrow \beta^\circ\gamma^\circ\delta^\circ) \rightarrow \alpha^\circ\beta^\circ\gamma^\circ\delta^\circ & (\beta^\circ\gamma^\circ\delta^\circ \rightarrow \gamma\beta) \rightarrow \alpha^\circ & (\delta^\circ \rightarrow \beta^\circ\gamma^\circ) \rightarrow \alpha^\circ\beta^\circ\gamma^\circ
\end{array}$$

$$\begin{array}{ccc}
0 & 000 & 001 \\
00 & & \\
\downarrow & & \\
(\gamma\beta\alpha \rightarrow \delta) \rightarrow \beta^\circ\gamma^\circ & (\delta\gamma\beta\alpha \rightarrow \delta^\circ) \rightarrow \beta^\circ\gamma^\circ\delta^\circ & (\alpha^\circ\beta^\circ\gamma^\circ \rightarrow \delta\gamma\beta\alpha) \rightarrow \alpha
\end{array}$$

$$\begin{array}{ccc}
000 & 001 & 0 \\
001 & 0 & 000 \\
001 & 000 & 0
\end{array}$$

$$\begin{array}{ccc}
00 & 00 & 00 \\
\downarrow & \downarrow & \downarrow \\
(\delta \rightarrow \alpha^\circ \beta^\circ \gamma^\circ \delta^\circ) \rightarrow \beta^\circ \gamma^\circ \delta^\circ & (\alpha^\circ \beta^\circ \gamma^\circ \delta^\circ \rightarrow \gamma \beta \alpha) \rightarrow \alpha & (\delta^\circ \rightarrow \alpha^\circ \beta^\circ \gamma^\circ) \rightarrow \beta^\circ \gamma^\circ
\end{array}$$

$$\begin{array}{ccc}
0 & 00 & 001 \\
000 & & \\
\downarrow & & \\
(\alpha \rightarrow \delta \gamma \beta) \rightarrow \gamma \beta & (\delta \gamma \beta \alpha \rightarrow \beta^\circ \gamma^\circ \delta^\circ) \rightarrow \delta^\circ & (\alpha^\circ \rightarrow \delta \gamma \beta \alpha) \rightarrow \alpha^\circ \beta^\circ \gamma^\circ
\end{array}$$

$$\begin{array}{ccc}
00 & 001 & 0 \\
000 & & \\
\downarrow & & \\
(\delta \gamma \beta \rightarrow \alpha^\circ \beta^\circ \gamma^\circ \delta^\circ) \rightarrow \delta^\circ & (\alpha^\circ \beta^\circ \gamma^\circ \delta^\circ \rightarrow \alpha) \rightarrow \gamma \beta \alpha & (\beta^\circ \gamma^\circ \delta^\circ \rightarrow \alpha^\circ) \rightarrow \gamma \beta
\end{array}$$

$$\begin{array}{ccc}
0 & 00 & 000 \\
001 & & \\
\downarrow & & \\
(\alpha \rightarrow \gamma \beta) \rightarrow \delta \gamma \beta & (\gamma \beta \alpha \rightarrow \beta^\circ \gamma^\circ) \rightarrow \delta & (\alpha^\circ \rightarrow \gamma \beta \alpha) \rightarrow \delta \gamma \beta \alpha
\end{array}$$

$$\begin{array}{ccc}
00 & 000 & 0 \\
001 & & \\
\downarrow & & \\
(\gamma \beta \rightarrow \alpha^\circ \beta^\circ \gamma^\circ) \rightarrow \delta & (\alpha^\circ \beta^\circ \gamma^\circ \rightarrow \alpha) \rightarrow \delta \gamma \beta \alpha & (\beta^\circ \gamma^\circ \rightarrow \alpha^\circ) \rightarrow \delta \gamma \beta
\end{array}$$

3.5. R = (0, 00, 000, 012)

$$\begin{array}{ccc}
00 & 000 & 012 \\
0 & & \\
\downarrow & & \\
(\gamma \beta \rightarrow \varepsilon \delta) \rightarrow \alpha^\circ \beta^\circ \gamma^\circ & (\varepsilon \delta \gamma \beta \rightarrow \delta^\circ \varepsilon^\circ) \rightarrow \alpha^\circ \beta^\circ \gamma^\circ \delta^\circ \varepsilon^\circ & (\beta^\circ \gamma^\circ \rightarrow \varepsilon \delta \gamma \beta) \rightarrow \alpha^\circ
\end{array}$$

$$\begin{array}{ccc}
000 & 012 & 00 \\
0 & & \\
\downarrow & & \\
(\varepsilon \delta \rightarrow \beta^\circ \gamma^\circ \delta^\circ \varepsilon^\circ) \rightarrow \alpha^\circ \beta^\circ \gamma^\circ \delta^\circ \varepsilon^\circ & (\beta^\circ \gamma^\circ \delta^\circ \varepsilon^\circ \rightarrow \gamma \beta) & (\delta^\circ \varepsilon^\circ \rightarrow \beta^\circ \gamma^\circ) \rightarrow \alpha^\circ \beta^\circ \gamma^\circ
\end{array}$$

$$\begin{array}{ccc}
0 & 000 & 012 \\
0 & 012 & 000 \\
000 & 0 & 012
\end{array}$$

$$\begin{array}{ccc}
00 & 00 & 00 \\
\downarrow & \downarrow & \downarrow \\
(\gamma\beta\alpha \rightarrow \varepsilon\delta) \rightarrow \beta^\circ\gamma^\circ & (\varepsilon\delta\gamma\beta\alpha \rightarrow \delta^\circ\varepsilon^\circ) \rightarrow \beta^\circ\gamma^\circ\delta^\circ\varepsilon^\circ & (\alpha^\circ\beta^\circ\gamma^\circ \rightarrow \varepsilon\delta\gamma\beta\alpha) \rightarrow \alpha
\end{array}$$

$$\begin{array}{ccc}
000 & 012 & 0 \\
00 & & \\
\downarrow & & \\
(\varepsilon\delta \rightarrow \alpha^\circ\beta^\circ\gamma^\circ\delta^\circ\varepsilon^\circ) \rightarrow \beta^\circ\gamma^\circ\delta^\circ\varepsilon^\circ & (\alpha^\circ\beta^\circ\gamma^\circ\delta^\circ\varepsilon^\circ \rightarrow \gamma\beta\alpha) \rightarrow \alpha & (\delta^\circ\varepsilon^\circ \rightarrow \alpha^\circ\beta^\circ\gamma^\circ) \rightarrow \beta^\circ\gamma^\circ
\end{array}$$

$$\begin{array}{ccc}
0 & 00 & 012 \\
000 & & \\
\downarrow & & \\
(\alpha \rightarrow \varepsilon\delta\gamma\beta) \rightarrow \gamma\beta & (\varepsilon\delta\gamma\beta\alpha \rightarrow \beta^\circ\gamma^\circ\delta^\circ\varepsilon^\circ) \rightarrow \delta^\circ\varepsilon^\circ & (\alpha^\circ \rightarrow \varepsilon\delta\gamma\beta\alpha) \rightarrow \gamma\beta\alpha
\end{array}$$

$$\begin{array}{ccc}
00 & 012 & 0 \\
000 & & \\
\downarrow & & \\
(\varepsilon\delta\gamma\beta \rightarrow \alpha^\circ\beta^\circ\gamma^\circ\delta^\circ\varepsilon^\circ) \rightarrow \delta^\circ\varepsilon^\circ & (\alpha^\circ\beta^\circ\gamma^\circ\delta^\circ\varepsilon^\circ \rightarrow \alpha) \rightarrow \gamma\beta\alpha & (\beta^\circ\gamma^\circ\delta^\circ\varepsilon^\circ \rightarrow \alpha^\circ) \rightarrow \beta
\end{array}$$

$$\begin{array}{ccc}
0 & 00 & 000 \\
012 & & \\
\downarrow & & \\
(\alpha, \gamma\beta) \rightarrow \varepsilon\delta\gamma\beta & (\gamma\beta\alpha \rightarrow \beta^\circ\gamma^\circ) \rightarrow \varepsilon\delta & (\alpha^\circ \rightarrow \gamma\beta\alpha) \rightarrow \varepsilon\delta\gamma\beta\alpha
\end{array}$$

$$\begin{array}{ccc}
00 & 000 & 0 \\
012 & & \\
\downarrow & & \\
(\gamma\beta \rightarrow \alpha^\circ\beta^\circ\gamma^\circ) \rightarrow \varepsilon\delta & (\alpha^\circ\beta^\circ\gamma^\circ \rightarrow \alpha) \rightarrow \varepsilon\delta\gamma\beta\alpha & (\beta^\circ\gamma^\circ \rightarrow \alpha^\circ) \rightarrow \varepsilon\delta\gamma\beta
\end{array}$$

3.6. R = (0, 00, 001, 012)

$$\begin{array}{ccc}
00 & 001 & 012 \\
0 & & \\
\downarrow & & \\
(\delta\gamma\beta \rightarrow \varepsilon) \rightarrow \alpha^\circ\beta^\circ\gamma^\circ\delta^\circ & (\varepsilon\delta\gamma\beta \rightarrow \varepsilon^\circ) \rightarrow \alpha^\circ\beta^\circ\gamma^\circ\delta^\circ\varepsilon^\circ & (\beta^\circ\gamma^\circ\delta^\circ \rightarrow \varepsilon\delta\gamma\beta) \rightarrow \alpha^\circ
\end{array}$$

$$\begin{array}{ccc}
001 & 012 & 00 \\
012 & 00 & 001 \\
012 & 001 & 00
\end{array}$$

$$\begin{array}{ccc}
0 & 0 & 0 \\
\downarrow & \downarrow & \downarrow \\
(\varepsilon \rightarrow \beta^\circ \gamma^\circ \delta^\circ \varepsilon^\circ) \rightarrow \alpha^\circ \beta^\circ \gamma^\circ \delta^\circ & (\beta^\circ \gamma^\circ \delta^\circ \varepsilon^\circ \rightarrow \delta \gamma \beta) \rightarrow \alpha^\circ & (\varepsilon^\circ \rightarrow \beta^\circ \gamma^\circ \delta^\circ) \rightarrow \alpha^\circ \beta^\circ \gamma^\circ \delta^\circ
\end{array}$$

$$\begin{array}{ccc}
0 & 001 & 012 \\
00 & & \\
\downarrow & & \\
(\delta \gamma \beta \alpha \rightarrow \varepsilon) \rightarrow \beta^\circ \gamma^\circ \delta^\circ & (\varepsilon \delta \gamma \beta \alpha \rightarrow \varepsilon^\circ) \rightarrow \beta^\circ \gamma^\circ \delta^\circ \varepsilon^\circ & (\alpha^\circ \beta^\circ \gamma^\circ \delta^\circ \rightarrow \varepsilon \delta \gamma \beta \alpha) \rightarrow \alpha
\end{array}$$

$$\begin{array}{ccc}
001 & 012 & 0 \\
00 & & \\
\downarrow & & \\
(\varepsilon \rightarrow \alpha^\circ \beta^\circ \gamma^\circ \delta^\circ \varepsilon^\circ) \rightarrow \beta^\circ \gamma^\circ \delta^\circ \varepsilon^\circ & (\alpha^\circ \beta^\circ \gamma^\circ \delta^\circ \varepsilon^\circ \rightarrow \delta \gamma \beta \alpha) \rightarrow \alpha & (\varepsilon^\circ \rightarrow \alpha^\circ \beta^\circ \gamma^\circ \delta^\circ) \rightarrow \beta^\circ \gamma^\circ \delta^\circ
\end{array}$$

$$\begin{array}{ccc}
0 & 00 & 012 \\
001 & & \\
\downarrow & & \\
(\alpha \rightarrow \varepsilon \delta \gamma \beta) \rightarrow \delta \gamma \beta & (\varepsilon \delta \gamma \beta \alpha \rightarrow \varepsilon \delta \gamma \beta) \rightarrow \varepsilon^\circ & (\alpha^\circ \rightarrow \varepsilon \delta \gamma \beta \alpha) \rightarrow \delta \gamma \beta \alpha
\end{array}$$

$$\begin{array}{ccc}
00 & 012 & 0 \\
001 & & \\
\downarrow & & \\
(\varepsilon \delta \gamma \beta \rightarrow \alpha^\circ \beta^\circ \gamma^\circ \delta^\circ \varepsilon^\circ) \rightarrow \varepsilon^\circ & (\alpha^\circ \beta^\circ \gamma^\circ \delta^\circ \varepsilon^\circ \rightarrow \alpha) \rightarrow \delta \gamma \beta \alpha & (\beta^\circ \gamma^\circ \delta^\circ \varepsilon^\circ \rightarrow \alpha^\circ) \rightarrow \varepsilon \delta \gamma \beta
\end{array}$$

$$\begin{array}{ccc}
0 & 00 & 001 \\
012 & & \\
\downarrow & & \\
(\alpha \rightarrow \delta \gamma \beta) \rightarrow \varepsilon \delta \gamma \beta & (\delta \gamma \beta \alpha \rightarrow \beta^\circ \gamma^\circ \delta^\circ) \rightarrow \varepsilon & (\alpha^\circ \rightarrow \delta \gamma \beta \alpha) \rightarrow \varepsilon \delta \gamma \beta \alpha
\end{array}$$

$$\begin{array}{ccc}
00 & 001 & 0 \\
012 & & \\
\downarrow & & \\
(\delta \gamma \beta \rightarrow \alpha^\circ \beta^\circ \gamma^\circ \delta^\circ) \rightarrow \varepsilon & (\alpha^\circ \beta^\circ \gamma^\circ \delta^\circ \rightarrow \alpha) \rightarrow \varepsilon \delta \gamma \beta \alpha & (\beta^\circ \gamma^\circ \delta^\circ \rightarrow \alpha^\circ) \rightarrow \varepsilon \delta \gamma \beta
\end{array}$$

3.7. R = (0, 01, 000, 001)

01 000 001 0 ↓ ($\gamma \rightarrow \delta$) \rightarrow $\alpha^\circ \beta^\circ \gamma^\circ$	01 001 000 0 ↓ ($\delta \gamma \rightarrow \delta^\circ$) \rightarrow $\alpha^\circ \beta^\circ \gamma^\circ \delta^\circ$	000 01 001 0 ↓ ($\gamma^\circ \rightarrow \delta \gamma$) \rightarrow $\alpha^\circ \beta^\circ$
000 001 01 0 ↓ ($\delta \rightarrow \gamma^\circ \delta^\circ$) \rightarrow $\alpha^\circ \beta^\circ \gamma^\circ \delta^\circ$	001 01 000 0 ↓ ($\gamma^\circ \delta^\circ \rightarrow \gamma$) \rightarrow $\alpha^\circ \beta^\circ$	001 000 01 0 ↓ ($\delta^\circ \rightarrow \gamma^\circ$) \rightarrow $\alpha^\circ \beta^\circ \gamma^\circ$
0 000 001 01 ↓ ($\gamma \beta \alpha \rightarrow \delta$) \rightarrow γ°	0 001 000 01 ↓ ($\delta \gamma \beta \alpha \rightarrow \delta^\circ$) \rightarrow $\gamma^\circ \delta^\circ$	000 0 001 01 ↓ ($\alpha^\circ \beta^\circ \gamma^\circ \rightarrow \delta \gamma \beta \alpha$) \rightarrow $\beta \alpha$
000 001 0 01 ↓ ($\delta \rightarrow \alpha^\circ \beta^\circ \gamma^\circ \delta^\circ$) \rightarrow $\gamma^\circ \delta^\circ$	001 0 000 01 ↓ ($\alpha^\circ \beta^\circ \gamma^\circ \delta^\circ \rightarrow \gamma \beta \alpha$) \rightarrow $\beta \alpha$	001 000 0 01 ↓ ($\delta^\circ \rightarrow \alpha^\circ \beta^\circ \gamma^\circ$) \rightarrow γ°
0 01 001 000 ↓ ($\beta \alpha \rightarrow \delta \gamma$) \rightarrow γ	0 001 01 000 ↓ ($\delta \gamma \beta \alpha \rightarrow \gamma^\circ \delta^\circ$) \rightarrow δ°	01 0 001 000 ↓ ($\alpha^\circ \beta^\circ \rightarrow \delta \gamma \beta \alpha$) \rightarrow $\gamma \beta \alpha$
01 001 0 000 ↓ ($\delta \gamma \rightarrow \alpha^\circ \beta^\circ \gamma^\circ \delta^\circ$) \rightarrow δ°	001 0 01 000 ↓ ($\alpha^\circ \beta^\circ \gamma^\circ \delta^\circ \rightarrow \beta \alpha$) \rightarrow $\gamma \beta \alpha$	001 01 0 000 ↓ ($\gamma^\circ \delta^\circ \rightarrow \alpha^\circ \beta^\circ$) \rightarrow γ
0 01 000 001 ↓ ($\beta \alpha \rightarrow \gamma$) \rightarrow $\delta \gamma$	0 000 01 001 ↓ ($\gamma \beta \alpha \rightarrow \gamma^\circ$) \rightarrow δ	01 0 000 001 ↓ ($\alpha^\circ \beta^\circ \rightarrow \gamma \beta \alpha$) \rightarrow $\delta \gamma \beta \alpha$
01 000 0	000 0 01	000 01 0

$$\begin{array}{ccc}
001 & 001 & 001 \\
\downarrow & \downarrow & \downarrow \\
(\gamma \rightarrow \alpha^\circ \beta^\circ \gamma^\circ) \rightarrow \delta & (\alpha^\circ \beta^\circ \gamma^\circ \rightarrow \beta\alpha) \rightarrow \delta\gamma\beta\alpha & (\gamma^\circ \rightarrow \alpha^\circ \beta^\circ) \rightarrow \delta\gamma
\end{array}$$

3.8. R = (0, 01, 000, 012)

$$\begin{array}{ccc}
01 & 000 & 012 & 01 & 012 & 000 & 000 & 01 & 012 \\
0 & & & 0 & & & 0 & & \\
\downarrow & & & \downarrow & & & \downarrow & & \\
(\gamma \rightarrow \varepsilon\delta) \rightarrow \alpha^\circ \beta^\circ \gamma^\circ & & & (\varepsilon\delta\gamma \rightarrow \delta^\circ \varepsilon^\circ) \rightarrow \alpha^\circ \beta^\circ \gamma^\circ \delta^\circ \varepsilon^\circ & & & (\gamma^\circ \rightarrow \varepsilon\delta\gamma) \rightarrow \alpha^\circ \beta^\circ & &
\end{array}$$

$$\begin{array}{ccc}
000 & 012 & 01 & 012 & 01 & 000 & 012 & 000 & 01 \\
0 & & & 0 & & & 0 & & \\
\downarrow & & & \downarrow & & & \downarrow & & \\
(\varepsilon\delta \rightarrow \gamma^\circ \delta^\circ \varepsilon^\circ) \rightarrow \alpha^\circ \beta^\circ \gamma^\circ \delta^\circ \varepsilon^\circ & & & (\gamma^\circ \delta^\circ \varepsilon^\circ \rightarrow \gamma) \rightarrow \alpha^\circ \beta^\circ & & & (\delta^\circ \varepsilon^\circ \rightarrow \gamma^\circ) \rightarrow \alpha^\circ \beta^\circ \gamma^\circ & &
\end{array}$$

$$\begin{array}{ccc}
0 & 000 & 012 & 0 & 012 & 000 & 000 & 0 & 012 \\
01 & & & 01 & & & 01 & & \\
\downarrow & & & \downarrow & & & \downarrow & & \\
(\gamma\beta\alpha \rightarrow \varepsilon\delta) \rightarrow \gamma^\circ & & & (\varepsilon\delta\gamma\beta\alpha \rightarrow \delta^\circ \varepsilon^\circ) \rightarrow \gamma^\circ \delta^\circ \varepsilon^\circ & & & (\alpha^\circ \beta^\circ \gamma^\circ \rightarrow \varepsilon\delta\gamma\beta\alpha) \rightarrow \beta\alpha & &
\end{array}$$

$$\begin{array}{ccc}
000 & 012 & 0 & 012 & 0 & 000 & 012 & 000 & 0 \\
01 & & & 01 & & & 01 & & \\
\downarrow & & & \downarrow & & & \downarrow & & \\
(\varepsilon\delta \rightarrow \alpha^\circ \beta^\circ \gamma^\circ \delta^\circ \varepsilon^\circ) \rightarrow \gamma^\circ \delta^\circ \varepsilon^\circ & & & (\alpha^\circ \beta^\circ \gamma^\circ \delta^\circ \varepsilon^\circ \rightarrow \gamma\beta\alpha) \rightarrow \beta\alpha & & & (\delta^\circ \varepsilon^\circ \rightarrow \alpha^\circ \beta^\circ \gamma^\circ) \rightarrow \gamma^\circ & &
\end{array}$$

$$\begin{array}{ccc}
0 & 01 & 012 & 0 & 012 & 01 & 01 & 0 & 012 \\
000 & & & 000 & & & 000 & & \\
\downarrow & & & \downarrow & & & \downarrow & & \\
(\beta\alpha \rightarrow \varepsilon\delta\gamma) \rightarrow \gamma & & & (\varepsilon\delta\gamma\beta\alpha \rightarrow \gamma^\circ \delta^\circ \varepsilon^\circ) \rightarrow \delta^\circ \varepsilon^\circ & & & (\alpha^\circ \beta^\circ \rightarrow \varepsilon\delta\gamma\beta\alpha) \rightarrow \gamma\beta\alpha & &
\end{array}$$

$$\begin{array}{ccc}
01 & 012 & 0 & 012 & 0 & 01 & 012 & 01 & 0 \\
000 & & & 000 & & & 000 & & \\
\downarrow & & & \downarrow & & & \downarrow & & \\
(\varepsilon\delta\gamma \rightarrow \alpha^\circ \beta^\circ \gamma^\circ \delta^\circ \varepsilon^\circ) \rightarrow \delta^\circ \varepsilon^\circ & & & (\delta^\circ \varepsilon^\circ \rightarrow \beta\alpha) \rightarrow \gamma\beta\alpha & & & (\gamma^\circ \delta^\circ \varepsilon^\circ \rightarrow \alpha^\circ \beta^\circ) \rightarrow \gamma & &
\end{array}$$

$$\begin{array}{ccc}
0 & 01 & 000 & 0 & 000 & 01 & 01 & 0 & 000
\end{array}$$

012 ↓ (βα → γ) → εδγ	012 ↓ (γβα → γ°) → εδ	012 ↓ (α°β° → γβα) → εδγβα
01 000 0 012 ↓ (γ → α°β°γ°) → εδ	000 0 01 012 ↓ (α°β°γ° → βα) → εδγβα	000 01 0 012 ↓ (γ → α°β°) → εδγ

3.9. R = (0, 01, 001, 012)

01 001 012 0 (δγ → ε) → α°β°γ°δ°	01 012 001 0 (εδγ → ε°) → α°β°γ°δ°ε°	001 01 012 0 (γ°δ° → εδγ) → α°β°
001 012 01 0 ↓ (ε → γ°δ°ε°) → α°β°γ°δ°ε°	012 01 001 0 ↓ (α°β°γ°δ°ε° → δγ) → α°β°	012 001 01 0 ↓ (ε° → γ°δ°) → α°β°γ°δ°
0 001 012 01 ↓ (δγβα → ε) → γ°δ°	0 012 001 01 ↓ (εδγβα → ε°) → γ°δ°ε°	001 0 012 01 ↓ (α°β°γ°δ° → εδγβα) → βα
001 012 0 01 ↓ (ε → α°β°γ°δ°ε°) → γ°δ°ε°	012 0 001 01 ↓ (α°β°γ°δ°ε° → δγβα) → βα	012 001 0 01 ↓ (ε° → α°β°γ°δ°) → γ°δ°
0 01 012 001 ↓ (βα → εδγ) → δγ	0 012 01 001 ↓ (εδγβα → γ°δ°ε°) → ε°	01 0 012 001 ↓ (α°β° → εδγβα) → δγβα
01 012 0	012 0 01	012 01 0

001	001	001
↓	↓	↓
$(\varepsilon\delta\gamma \rightarrow \alpha^\circ\beta^\circ\gamma^\circ\delta^\circ\varepsilon^\circ) \rightarrow \varepsilon^\circ$	$(\alpha^\circ\beta^\circ\gamma^\circ\delta^\circ\varepsilon^\circ \rightarrow \beta\alpha) \rightarrow \delta\gamma\beta\alpha$	$(\gamma^\circ\delta^\circ\varepsilon^\circ \rightarrow \alpha^\circ\beta^\circ) \rightarrow \delta\gamma$

0 01 001	0 001 01	01 0 001
012	012	012
↓	↓	↓
$(\beta\alpha \rightarrow \delta\gamma) \rightarrow \varepsilon\delta\gamma$	$(\delta\gamma\beta\alpha \rightarrow \gamma^\circ\delta^\circ) \rightarrow \varepsilon$	$(\alpha^\circ\beta^\circ \rightarrow \delta\gamma\beta\alpha) \rightarrow \varepsilon\delta\gamma\beta\alpha$

01 001 0	001 0 01	001 01 0
012	012	012
↓	↓	↓
$(\delta\gamma \rightarrow \alpha^\circ\beta^\circ\gamma^\circ\delta^\circ) \rightarrow \varepsilon$	$(\delta\gamma\beta\alpha \rightarrow \beta\alpha) \rightarrow \varepsilon\delta\gamma\beta\alpha$	$(\gamma^\circ\delta^\circ \rightarrow \alpha^\circ\beta^\circ) \rightarrow \varepsilon\delta\gamma$

3.10. R = (0, 000, 001, 012)

000 001 012	000 012 001	001 000 012
0	0	0
↓	↓	↓
$(\delta \rightarrow \varepsilon) \rightarrow \alpha^\circ\beta^\circ\gamma^\circ\delta^\circ$	$(\varepsilon\delta \rightarrow \varepsilon^\circ) \rightarrow \alpha^\circ\beta^\circ\gamma^\circ\delta^\circ\varepsilon^\circ$	$(\delta^\circ \rightarrow \varepsilon\delta) \rightarrow \alpha^\circ\beta^\circ\gamma^\circ$

001 012 000	012 000 001	012 001 000
0	0	0
↓	↓	↓
$(\varepsilon \rightarrow \delta^\circ\varepsilon^\circ) \rightarrow \alpha^\circ\beta^\circ\gamma^\circ\delta^\circ\varepsilon^\circ$	$(\delta^\circ\varepsilon^\circ \rightarrow \delta^\circ) \rightarrow \alpha^\circ\beta^\circ\gamma^\circ$	$(\varepsilon^\circ \rightarrow \delta^\circ) \rightarrow \alpha^\circ\beta^\circ\gamma^\circ\delta^\circ$

0 001 012	0 012 001	001 0 012
000	000	000
↓	↓	↓
$(\delta\gamma\beta\alpha \rightarrow \varepsilon) \rightarrow \delta^\circ$	$(\varepsilon\delta\gamma\beta\alpha \rightarrow \varepsilon^\circ) \rightarrow \delta^\circ\varepsilon^\circ$	$(\alpha^\circ\beta^\circ\gamma^\circ\delta^\circ \rightarrow \varepsilon\delta\gamma\beta\alpha) \rightarrow \gamma\beta\alpha$

001 012 0	012 0 001	012 001 0
000	000	000
↓	↓	↓
$(\varepsilon \rightarrow \alpha^\circ\beta^\circ\gamma^\circ\delta^\circ\varepsilon^\circ) \rightarrow \delta^\circ\varepsilon^\circ$		
$(\alpha^\circ\beta^\circ\gamma^\circ\delta^\circ\varepsilon^\circ \rightarrow \delta\gamma\beta\alpha) \rightarrow \gamma\beta\alpha$		
$(\varepsilon^\circ \rightarrow \alpha^\circ\beta^\circ\gamma^\circ\delta^\circ) \rightarrow \delta^\circ$		

0 000 012	0 012 000	000 0 012
-----------	-----------	-----------

$\begin{array}{c} 001 \\ \downarrow \\ (\gamma\beta\alpha \rightarrow \varepsilon\delta) \rightarrow \delta \end{array}$	$\begin{array}{c} 001 \\ \downarrow \\ (\varepsilon\delta\gamma\beta\alpha \rightarrow \delta^\circ\varepsilon^\circ) \rightarrow \varepsilon^\circ \end{array}$	$\begin{array}{c} 001 \\ \downarrow \\ (\alpha^\circ\beta^\circ\gamma^\circ \rightarrow \varepsilon\delta\gamma\beta\alpha) \rightarrow \delta\gamma\beta\alpha \end{array}$
$\begin{array}{c} 000 \quad 012 \quad 0 \\ \quad 001 \\ \downarrow \\ (\varepsilon\delta \rightarrow \alpha^\circ\beta^\circ\gamma^\circ\delta^\circ\varepsilon^\circ) \rightarrow \varepsilon^\circ \end{array}$	$\begin{array}{c} 012 \quad 0 \quad 000 \\ \quad 001 \\ \downarrow \\ (\alpha^\circ\beta^\circ\gamma^\circ\delta^\circ\varepsilon^\circ \rightarrow \gamma\beta\alpha) \rightarrow \alpha^\circ\beta^\circ\gamma^\circ\delta^\circ \end{array}$	$\begin{array}{c} 012 \quad 000 \quad 0 \\ \quad 001 \\ \downarrow \\ (\delta^\circ\varepsilon^\circ \rightarrow \alpha^\circ\beta^\circ\gamma^\circ) \rightarrow \delta \end{array}$
$\begin{array}{c} 0 \quad 000 \quad 001 \\ \quad 012 \\ \downarrow \\ (\gamma\beta\alpha \rightarrow \delta) \rightarrow \varepsilon\delta \end{array}$	$\begin{array}{c} 0 \quad 001 \quad 000 \\ \quad 012 \\ \downarrow \\ (\delta\gamma\beta\alpha \rightarrow \delta^\circ) \rightarrow \varepsilon \end{array}$	$\begin{array}{c} 000 \quad 0 \quad 001 \\ \quad 012 \\ \downarrow \\ (\alpha^\circ\beta^\circ\gamma^\circ \rightarrow \delta\gamma\beta\alpha) \rightarrow \varepsilon\delta\gamma\beta\alpha \end{array}$
$\begin{array}{c} 000 \quad 001 \quad 0 \\ \quad 012 \\ \downarrow \\ (\delta \rightarrow \alpha^\circ\beta^\circ\gamma^\circ\delta^\circ) \rightarrow \varepsilon \end{array}$	$\begin{array}{c} 001 \quad 0 \quad 000 \\ \quad 012 \\ \downarrow \\ (\alpha^\circ\beta^\circ\gamma^\circ\delta^\circ \rightarrow \gamma\beta\alpha) \rightarrow \varepsilon\delta\gamma\beta\alpha \end{array}$	$\begin{array}{c} 001 \quad 000 \quad 0 \\ \quad 012 \\ \downarrow \\ (\delta^\circ \rightarrow \alpha^\circ\beta^\circ\gamma^\circ) \rightarrow \varepsilon\delta \end{array}$

3.11. R = (00, 01, 000, 001)

$\begin{array}{c} 01 \quad 000 \quad 001 \\ \quad 00 \\ \downarrow \\ (\gamma \rightarrow \delta) \rightarrow \beta^\circ\gamma^\circ \end{array}$	$\begin{array}{c} 01 \quad 001 \quad 000 \\ \quad 00 \\ \downarrow \\ (\delta\gamma \rightarrow \delta^\circ) \rightarrow \beta^\circ\gamma^\circ\delta^\circ \end{array}$	$\begin{array}{c} 000 \quad 01 \quad 001 \\ \quad 00 \\ \downarrow \\ (\gamma^\circ \rightarrow \delta\gamma) \rightarrow \beta^\circ \end{array}$
$\begin{array}{c} 000 \quad 001 \quad 01 \\ \quad 00 \\ \downarrow \\ (\delta \rightarrow \gamma^\circ\delta^\circ) \rightarrow \beta^\circ\gamma^\circ\delta^\circ \end{array}$	$\begin{array}{c} 001 \quad 01 \quad 000 \\ \quad 00 \\ \downarrow \\ (\gamma^\circ\delta^\circ \rightarrow \gamma) \rightarrow \beta^\circ \end{array}$	$\begin{array}{c} 001 \quad 000 \quad 01 \\ \quad 00 \\ \downarrow \\ (\delta^\circ \rightarrow \gamma^\circ) \rightarrow \beta^\circ\gamma^\circ \end{array}$
$\begin{array}{c} 00 \quad 000 \quad 001 \\ \quad 01 \\ \downarrow \\ (\gamma\beta \rightarrow \delta) \rightarrow \gamma^\circ \end{array}$	$\begin{array}{c} 00 \quad 001 \quad 000 \\ \quad 01 \\ \downarrow \\ (\delta\gamma\beta \rightarrow \delta^\circ) \rightarrow \gamma^\circ\delta^\circ \end{array}$	$\begin{array}{c} 000 \quad 00 \quad 001 \\ \quad 01 \\ \downarrow \\ (\beta^\circ\gamma^\circ \rightarrow \delta\gamma\beta) \rightarrow \beta \end{array}$
$000 \quad 001 \quad 00$	$001 \quad 00 \quad 000$	$001 \quad 000 \quad 00$

$\begin{array}{c} 01 \\ \downarrow \\ (\delta \rightarrow \beta^\circ \gamma^\circ \delta^\circ) \rightarrow \gamma^\circ \delta^\circ \end{array}$	$\begin{array}{c} 01 \\ \downarrow \\ (\beta^\circ \gamma^\circ \delta^\circ \rightarrow \gamma \beta) \rightarrow \beta \end{array}$	$\begin{array}{c} 01 \\ \downarrow \\ (\delta^\circ \rightarrow \beta^\circ \gamma^\circ) \rightarrow \gamma^\circ \end{array}$
$\begin{array}{ccc} 00 & 01 & 001 \\ & 000 & \\ \downarrow & & \\ (\beta \rightarrow \delta \gamma) \rightarrow \gamma \end{array}$	$\begin{array}{ccc} 00 & 001 & 01 \\ & 000 & \\ \downarrow & & \\ (\delta \gamma \beta \rightarrow \gamma^\circ \delta^\circ) \rightarrow \delta^\circ \end{array}$	$\begin{array}{ccc} 01 & 00 & 001 \\ & 000 & \\ \downarrow & & \\ (\beta^\circ \rightarrow \delta \gamma \beta) \rightarrow \gamma \beta \end{array}$
$\begin{array}{ccc} 01 & 001 & 00 \\ & 000 & \\ \downarrow & & \\ (\delta \gamma \rightarrow \beta^\circ \gamma^\circ \delta^\circ) \rightarrow \delta^\circ \end{array}$	$\begin{array}{ccc} 001 & 00 & 01 \\ & 000 & \\ \downarrow & & \\ (\beta^\circ \gamma^\circ \delta^\circ \rightarrow \beta) \rightarrow \gamma \beta \end{array}$	$\begin{array}{ccc} 001 & 01 & 00 \\ & 000 & \\ \downarrow & & \\ (\gamma^\circ \delta^\circ \rightarrow \beta^\circ) \rightarrow \gamma \end{array}$
$\begin{array}{ccc} 00 & 01 & 000 \\ & 001 & \\ \downarrow & & \\ (\beta \rightarrow \gamma) \rightarrow \delta \gamma \end{array}$	$\begin{array}{ccc} 00 & 000 & 01 \\ & 001 & \\ \downarrow & & \\ (\gamma \beta \rightarrow \gamma^\circ) \rightarrow \delta \end{array}$	$\begin{array}{ccc} 01 & 00 & 000 \\ & 001 & \\ \downarrow & & \\ (\beta^\circ \rightarrow \gamma \beta) \rightarrow \delta \gamma \beta \end{array}$
$\begin{array}{ccc} 01 & 000 & 00 \\ & 001 & \\ \downarrow & & \\ (\gamma \rightarrow \beta^\circ \gamma^\circ) \rightarrow \delta \end{array}$	$\begin{array}{ccc} 000 & 00 & 01 \\ & 001 & \\ \downarrow & & \\ (\beta^\circ \gamma^\circ \rightarrow \beta) \rightarrow \delta \gamma \beta \end{array}$	$\begin{array}{ccc} 000 & 01 & 00 \\ & 001 & \\ \downarrow & & \\ (\gamma^\circ \rightarrow \beta^\circ) \rightarrow \delta \gamma \end{array}$

3.12. R = (00, 01, 000, 012)

$\begin{array}{ccc} 01 & 000 & 012 \\ & 00 & \\ \downarrow & & \\ (\gamma \rightarrow \varepsilon \delta) \rightarrow \beta^\circ \gamma^\circ \end{array}$	$\begin{array}{ccc} 01 & 012 & 000 \\ & 00 & \\ \downarrow & & \\ (\varepsilon \delta \gamma \rightarrow \delta^\circ \varepsilon^\circ) \rightarrow \beta^\circ \gamma^\circ \delta^\circ \varepsilon^\circ \end{array}$	$\begin{array}{ccc} 000 & 01 & 012 \\ & 00 & \\ \downarrow & & \\ (\gamma^\circ \rightarrow \varepsilon \delta \gamma) \rightarrow \beta^\circ \end{array}$
$\begin{array}{ccc} 000 & 012 & 01 \\ & 00 & \\ \downarrow & & \\ (\varepsilon \delta \rightarrow \gamma^\circ \delta^\circ \varepsilon^\circ) \rightarrow \beta^\circ \gamma^\circ \delta^\circ \varepsilon^\circ \end{array}$	$\begin{array}{ccc} 012 & 01 & 000 \\ & 00 & \\ \downarrow & & \\ (\gamma^\circ \delta^\circ \varepsilon^\circ \rightarrow \gamma) \rightarrow \beta^\circ \end{array}$	$\begin{array}{ccc} 012 & 000 & 01 \\ & 00 & \\ \downarrow & & \\ (\delta^\circ \varepsilon^\circ \rightarrow \gamma^\circ) \rightarrow \beta^\circ \gamma^\circ \end{array}$
$\begin{array}{ccc} 00 & 000 & 012 \end{array}$	$\begin{array}{ccc} 00 & 012 & 000 \end{array}$	$\begin{array}{ccc} 000 & 00 & 012 \end{array}$

01 ↓ ($\gamma\beta \rightarrow \varepsilon\delta$) $\rightarrow \gamma^\circ$	01 ↓ ($\varepsilon\delta\gamma\beta \rightarrow \delta^\circ\varepsilon^\circ$) $\rightarrow \gamma^\circ\delta^\circ\varepsilon^\circ$ ($\beta^\circ\gamma^\circ \rightarrow \varepsilon\delta\gamma\beta$) $\rightarrow \beta$	01 ↓ ($\beta^\circ\gamma^\circ \rightarrow \varepsilon\delta\gamma\beta$) $\rightarrow \beta$
000 012 00 01 ↓ ($\varepsilon\delta \rightarrow \beta^\circ\gamma^\circ\delta^\circ\varepsilon^\circ$) $\rightarrow \gamma^\circ\delta^\circ\varepsilon^\circ$ ($\beta^\circ\gamma^\circ\delta^\circ\varepsilon^\circ \rightarrow \gamma\beta$) $\rightarrow \beta$	012 00 000 01 ↓ ($\beta^\circ\gamma^\circ\delta^\circ\varepsilon^\circ \rightarrow \gamma\beta$) $\rightarrow \beta$	012 000 00 01 ↓ ($\delta^\circ\varepsilon^\circ \rightarrow \beta^\circ\gamma^\circ$) $\rightarrow \gamma^\circ$
00 01 012 000 ↓ ($\beta \rightarrow \varepsilon\delta\gamma$) $\rightarrow \gamma$	00 012 01 000 ↓ ($\varepsilon\delta\gamma\beta \rightarrow \gamma^\circ\delta^\circ\varepsilon^\circ$) $\rightarrow \delta^\circ\varepsilon^\circ$ ($\beta^\circ \rightarrow \varepsilon\delta\gamma\beta$) $\rightarrow \gamma\beta$	01 00 012 000 ↓ ($\beta^\circ \rightarrow \varepsilon\delta\gamma\beta$) $\rightarrow \gamma\beta$
01 012 00 000 ↓ ($\varepsilon\delta\gamma \rightarrow \beta^\circ\gamma^\circ\delta^\circ\varepsilon^\circ$) $\rightarrow \delta^\circ\varepsilon^\circ$	012 00 01 000 ↓ ($\beta^\circ\gamma^\circ\delta^\circ\varepsilon^\circ \rightarrow \beta$) $\rightarrow \gamma\beta$	012 01 00 000 ↓ ($\gamma^\circ\delta^\circ\varepsilon^\circ \rightarrow \beta^\circ$) $\rightarrow \gamma$
00 01 000 012 ↓ ($\beta \rightarrow \gamma$) $\rightarrow \varepsilon\delta\gamma$	00 000 01 012 ↓ ($\gamma\beta \rightarrow \gamma^\circ$) $\rightarrow \varepsilon\delta$	01 00 000 012 ↓ ($\beta^\circ \rightarrow \gamma\beta$) $\rightarrow \varepsilon\delta\gamma\beta$
01 000 00 012 ↓ ($\gamma \rightarrow \beta^\circ\gamma^\circ$) $\rightarrow \varepsilon\delta$	000 00 01 012 ↓ ($\beta^\circ\gamma^\circ \rightarrow \beta$) $\rightarrow \varepsilon\delta\gamma\beta$	000 01 00 012 ↓ ($\gamma^\circ \rightarrow \beta^\circ$) $\rightarrow \varepsilon\delta\gamma$

3.13. R = (00, 01, 001, 012)

01 001 012 00 ↓ ($\delta\gamma \rightarrow \varepsilon$) $\rightarrow \beta^\circ\gamma^\circ\delta^\circ$	01 012 001 00 ↓ ($\varepsilon\delta\gamma \rightarrow \varepsilon^\circ$) $\rightarrow \beta^\circ\gamma^\circ\delta^\circ\varepsilon^\circ$	001 01 012 00 ↓ ($\gamma^\circ\delta^\circ \rightarrow \varepsilon\delta\gamma$) $\rightarrow \beta^\circ$
001 012 01	012 01 001	012 001 01

00 ↓ $(\varepsilon \rightarrow \gamma^\circ \delta^\circ \varepsilon^\circ) \rightarrow \beta^\circ \gamma^\circ \delta^\circ \varepsilon^\circ (\gamma^\circ \delta^\circ \varepsilon^\circ \rightarrow \delta \gamma) \rightarrow \beta^\circ$	00 ↓ $(\varepsilon^\circ \rightarrow \gamma^\circ \delta^\circ) \rightarrow \beta^\circ \gamma^\circ \delta^\circ$	00 ↓ $(\varepsilon^\circ \rightarrow \gamma^\circ \delta^\circ) \rightarrow \beta^\circ \gamma^\circ \delta^\circ$
00 001 012 01 ↓ $(\delta \gamma \beta \rightarrow \varepsilon) \rightarrow \gamma^\circ \delta^\circ$	00 012 001 01 ↓ $(\varepsilon \delta \gamma \beta \rightarrow \varepsilon^\circ) \rightarrow \gamma^\circ \delta^\circ \varepsilon^\circ$	001 00 012 01 ↓ $(\beta^\circ \gamma^\circ \delta^\circ \rightarrow \varepsilon \delta \gamma \beta) \rightarrow \beta$
001 012 00 01 ↓ $(\varepsilon \rightarrow \beta^\circ \gamma^\circ \delta^\circ \varepsilon^\circ) \rightarrow \gamma^\circ \delta^\circ \varepsilon^\circ (\beta^\circ \gamma^\circ \delta^\circ \varepsilon^\circ \rightarrow \delta \gamma \beta) \rightarrow \beta$	012 00 001 01 ↓ $(\varepsilon \rightarrow \beta^\circ \gamma^\circ \delta^\circ) \rightarrow \gamma^\circ \delta^\circ$	012 001 00 01 ↓ $(\varepsilon^\circ \rightarrow \beta^\circ \gamma^\circ \delta^\circ) \rightarrow \gamma^\circ \delta^\circ$
00 01 012 001 ↓ $(\beta \rightarrow \varepsilon \delta \gamma) \rightarrow \delta \gamma$	00 012 01 001 ↓ $(\varepsilon \delta \gamma \beta \rightarrow \gamma^\circ \delta^\circ \varepsilon^\circ) \rightarrow \varepsilon^\circ$	01 00 012 001 ↓ $(\beta^\circ \rightarrow \varepsilon \delta \gamma \beta) \rightarrow \delta \gamma \beta$
01 012 00 001 ↓ $(\varepsilon \delta \gamma \rightarrow \beta^\circ \gamma^\circ \delta^\circ \varepsilon^\circ) \rightarrow \varepsilon^\circ$	012 00 01 001 ↓ $(\beta^\circ \gamma^\circ \delta^\circ \varepsilon^\circ \rightarrow \beta) \rightarrow \delta \gamma \beta$	012 01 00 001 ↓ $(\gamma^\circ \delta^\circ \varepsilon^\circ \rightarrow \beta^\circ) \rightarrow \delta \gamma$
00 01 001 012 ↓ $(\beta \rightarrow \delta \gamma) \rightarrow \varepsilon \delta \gamma$	00 001 01 012 ↓ $(\delta \gamma \beta \rightarrow \gamma^\circ \delta^\circ) \rightarrow \varepsilon$	01 00 001 012 ↓ $(\beta^\circ \rightarrow \delta \gamma \beta) \rightarrow \varepsilon \delta \gamma \beta$
01 001 00 012 ↓ $(\delta \gamma \rightarrow \delta \gamma \beta) \rightarrow \varepsilon$	001 00 01 012 ↓ $(\beta^\circ \gamma^\circ \delta^\circ \rightarrow \beta) \rightarrow \varepsilon \delta \gamma \beta$	001 01 00 012 ↓ $(\gamma^\circ \delta^\circ \rightarrow \beta^\circ) \rightarrow \varepsilon \delta \gamma$

3.14. R= (00, 000, 001, 012)

000 001 012 00 ↓ $(\delta \rightarrow \varepsilon) \rightarrow \beta^\circ \gamma^\circ \delta^\circ$	000 012 001 00 ↓ $(\varepsilon \delta \rightarrow \varepsilon^\circ) \rightarrow \beta^\circ \gamma^\circ \delta^\circ \varepsilon^\circ$	001 000 012 00 ↓ $(\delta^\circ \rightarrow \varepsilon \delta) \rightarrow \beta^\circ \gamma^\circ$
001 012 000 00 ↓ $(\varepsilon \rightarrow \delta^\circ \varepsilon^\circ) \rightarrow \beta^\circ \gamma^\circ \delta^\circ \varepsilon^\circ$	012 000 001 00 ↓ $(\delta^\circ \varepsilon^\circ \rightarrow \delta) \rightarrow \beta^\circ \gamma^\circ$	012 001 000 00 ↓ $(\varepsilon^\circ \rightarrow \delta^\circ) \rightarrow \beta^\circ \gamma^\circ \delta^\circ$
00 001 012 000 ↓ $(\delta \gamma \beta \rightarrow \varepsilon) \rightarrow \delta^\circ$	00 012 001 000 ↓ $(\varepsilon \delta \gamma \beta \rightarrow \varepsilon^\circ) \rightarrow \delta^\circ \varepsilon^\circ$	001 00 012 000 ↓ $(\beta^\circ \gamma^\circ \delta^\circ \rightarrow \varepsilon \delta \gamma \beta) \rightarrow \gamma \beta$
001 012 00 000 ↓ $(\varepsilon \rightarrow \varepsilon \delta \gamma \beta) \rightarrow \delta^\circ \varepsilon^\circ$	012 00 001 000 ↓ $(\beta^\circ \gamma^\circ \delta^\circ \varepsilon^\circ \rightarrow \delta \gamma \beta) \rightarrow \gamma \beta$	012 001 00 000 ↓ $(\varepsilon^\circ \rightarrow \delta \gamma \beta) \rightarrow \delta^\circ$
00 000 012 001 ↓ $(\gamma \beta \rightarrow \varepsilon \delta) \rightarrow \delta$	00 012 000 001 ↓ $(\varepsilon \delta \gamma \beta \rightarrow \delta^\circ \varepsilon^\circ) \rightarrow \varepsilon^\circ$	000 00 012 001 ↓ $(\beta^\circ \gamma^\circ \rightarrow \varepsilon \delta \gamma \beta) \rightarrow \delta \gamma \beta$
000 012 00 001 ↓ $(\varepsilon \delta \rightarrow \beta^\circ \gamma^\circ \delta^\circ \varepsilon^\circ) \rightarrow \varepsilon^\circ$	012 00 000 001 ↓ $(\beta^\circ \gamma^\circ \delta^\circ \varepsilon^\circ \rightarrow \gamma \beta) \rightarrow \delta \gamma \beta$	012 000 00 001 ↓ $(\delta^\circ \varepsilon^\circ \rightarrow \beta^\circ \gamma^\circ) \rightarrow \delta$
00 000 001 012 ↓ $(\gamma \beta \rightarrow \delta) \rightarrow \varepsilon \delta$	00 001 000 012 ↓ $(\delta \gamma \beta \rightarrow \delta^\circ) \rightarrow \varepsilon$	000 00 001 012 ↓ $(\beta^\circ \gamma^\circ \rightarrow \delta \gamma \beta) \rightarrow \varepsilon \delta \gamma \beta$
000 001 00	001 00 000	001 000 00

012	012	012
↓	↓	↓
$(\delta \rightarrow \beta^\circ \gamma^\circ \delta^\circ) \rightarrow \varepsilon$	$(\beta^\circ \gamma^\circ \delta^\circ \rightarrow \gamma \beta) \rightarrow \varepsilon \delta \gamma \beta$	$(\delta^\circ \rightarrow \beta^\circ \gamma^\circ) \rightarrow \varepsilon \delta$

3.15. R = (01, 000, 001, 012)

000 001 012	000 012 001	001 000 012
01	01	01
↓	↓	↓
$(\delta \rightarrow \varepsilon) \rightarrow \gamma^\circ \delta^\circ$	$(\varepsilon \delta \rightarrow \varepsilon^\circ) \rightarrow \gamma^\circ \delta^\circ \varepsilon^\circ$	$(\delta^\circ \rightarrow \varepsilon \delta) \rightarrow \gamma^\circ$
001 012 000	012 000 001	012 001 000
01	01	01
↓	↓	↓
$(\varepsilon \rightarrow \delta^\circ \varepsilon^\circ) \rightarrow \gamma^\circ \delta^\circ \varepsilon^\circ$	$(\delta^\circ \varepsilon^\circ \rightarrow \delta) \rightarrow \gamma^\circ$	$(\varepsilon^\circ \rightarrow \delta^\circ) \rightarrow \gamma^\circ \delta^\circ$
01 001 012	01 012 001	001 01 012
000	000	000
↓	↓	↓
$(\delta \gamma \rightarrow \varepsilon) \rightarrow \delta^\circ$	$(\varepsilon \delta \gamma \rightarrow \varepsilon^\circ) \rightarrow \delta^\circ \varepsilon^\circ$	$(\gamma^\circ \delta^\circ \rightarrow \varepsilon \delta \gamma) \rightarrow \gamma$
001 012 01	012 01 001	012 001 01
000	000	000
↓	↓	↓
$(\varepsilon \rightarrow \gamma^\circ \delta^\circ \varepsilon^\circ) \rightarrow \delta^\circ \varepsilon^\circ$	$(\gamma^\circ \delta^\circ \varepsilon^\circ \rightarrow \delta \gamma) \rightarrow \gamma$	$(\varepsilon^\circ \rightarrow \gamma^\circ \delta^\circ) \rightarrow \delta^\circ$
01 000 012	01 012 000	000 01 012
001	001	012
↓	↓	↓
$(\gamma \rightarrow \varepsilon \delta) \rightarrow \delta$	$(\varepsilon \delta \gamma \rightarrow \delta^\circ \varepsilon^\circ) \rightarrow \varepsilon^\circ$	$(\gamma^\circ \rightarrow \varepsilon \delta \gamma) \rightarrow \varepsilon \delta \gamma$
000 012 01	012 01 000	012 000 01
001	001	001
↓	↓	↓
$(\varepsilon \rightarrow \gamma^\circ \delta^\circ \varepsilon^\circ) \rightarrow \varepsilon^\circ$	$(\gamma^\circ \delta^\circ \varepsilon^\circ \rightarrow \gamma) \rightarrow \delta \gamma$	$(\delta^\circ \varepsilon^\circ \rightarrow \gamma^\circ) \rightarrow \delta$
01 000 001	01 001 000	000 01 001

012 ↓ ($\gamma \rightarrow \delta$) $\rightarrow \varepsilon\delta$	012 ↓ ($\delta\gamma \rightarrow \delta^\circ$) $\rightarrow \varepsilon$	012 ↓ ($\gamma^\circ \rightarrow \delta\gamma$) $\rightarrow \varepsilon\delta\gamma$
000 001 01 012 ↓ ($\delta \rightarrow \gamma^\circ\delta^\circ$) $\rightarrow \varepsilon$	001 01 000 012 ↓ ($\gamma^\circ\delta^\circ \rightarrow \gamma$) $\rightarrow \varepsilon\delta\gamma$	001 000 01 012 ↓ ($\delta^\circ \rightarrow \gamma^\circ$) $\rightarrow \varepsilon\delta$

Literatur

- Gardner, Martin, Mathematical Games: The fantastic combinations of John Conway's new solitaire game "Life". In: Scientific American, vol. 223 (Oct. 1970), S. 120–123
- Kaehr, Rudolf, Kähr's Catalog of morphic CA-Patterns. Part V: Examples of rule-CIR and RCI. Glasgow 2015. Digitalisat:
http://www.vordenker.de/rk/rk_Kahrs-Catalog-of-morphic-CA-patterns_Part-V_2015.pdf (2015)
- Toth, Alfred, Polykontexturale semiotische Automaten. In: Electronic Journal for Mathematical Semiotics, 2019a
- Toth, Alfred, Die Autoreproduktion von Subzeichen in semiotischen Automaten. In: Electronic Journal for Mathematical Semiotics, 2019b
- Toth, Alfred, Die Autoreproduktion von Proto- und Deuterозahlen in semiotischen Automaten. In: Electronic Journal for Mathematical Semiotics, 2019c
- Toth, Alfred, Die Morphismen der Proto- und Deuterosemiotik. In: Electronic Journal for Mathematical Semiotics, 2019d
- Toth, Alfred, Grundlegung einer polykontexturalen Semiotik. Tucson, AZ, 2019 (= 2019e)
- von Neumann, John/A.W. Burks, Theory of Self-Reproducing Automata. Urbana, IL, 1966

System, Umgebung und ihre Vermittlung im kaehrschen diamond-Modell

1. Bekanntlich wurde der diamond von Rudolf Kaehr (2007) als Modell für eine qualitative Kategorientheorie eingeführt.

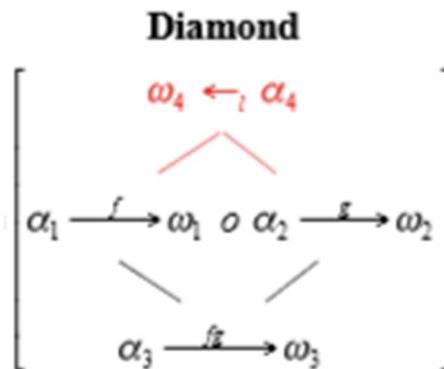

Ein diamond besteht in seiner unteren Hälfte aus einer Komposition (Konkatenation) regulärer morphismischer Abbildungen der Form

$$(a \rightarrow b) \circ (b \rightarrow c) = (a \rightarrow c),$$

die allerdings kontexturiert sind,

und in seiner oberen Hälfte aus der von Kaehr als Heteromorphismus bezeichneten Abbildung

$$(a \leftarrow c),$$

die ebenfalls kontexturiert ist, so daß

$$(a \rightarrow c)-1 \neq (a \leftarrow c).$$

Am besten hat diese polykontextural bedingte Nicht-Umkehrbarkeit Kaehr selbst am Beispiel der „diamondization of arithmetic“ dargestellt und kommentiert (vgl. Kaehr (2008, S. 72).

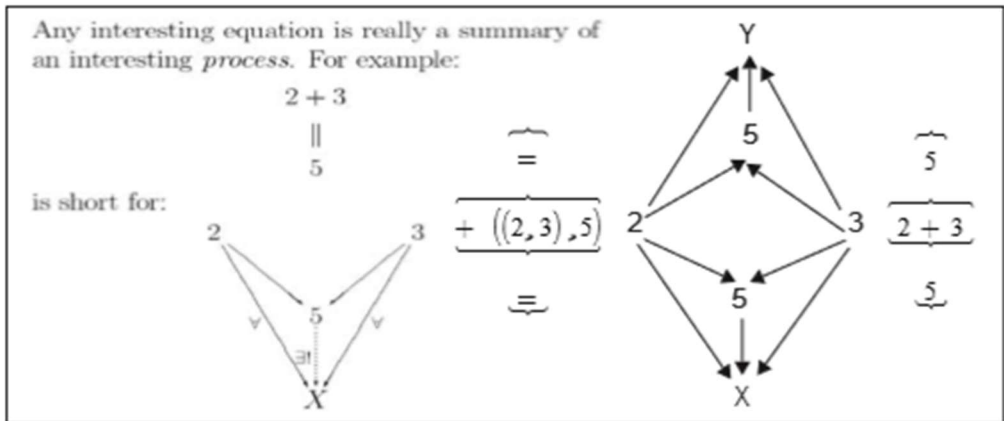

How is the diamond operation, $2+2=5$, to read? The first diagram gives an explanation of the processes involved into the addition. That is, for all numbers 2 of X and all numbers 3 of X there is exactly one number 5 of X representing the addition $2+3$. This is the classic operational or categorial approach to addition (Baez).

The second diagram shows the diamond representation of the addition $2+3$. The wordings are the same, one for X, and one for Y. The equation is *stable* in respect of the acceptational addition and the rejectional addition iff $X=Y$. That is, iff the numbers and the operations belong to isomorphic arithmetical systems, then they are equivalent. If X would be a totally different arithmetical system to Y then some disturbance of the harmony between both would happen. Nevertheless, because of their rejectional direction, numbers of Y might "run" in reverse order to X and coincide at the point of $X=Y$.

The meaning of a sign is defined by its use. Thus, the numeral "5" belonging to the system X, has not exactly the same meaning as the numeral "5" belonging to the system Y. They may be isomorphic, hetero-morphic, equivalent, but they are not equal. Equality is given intra-contextually for terms of X only, or for terms of Y only. But not for terms between X and Y. In other words, the equation is realized as an equivalence only if it has a model in the rejectional, i.e., in the environmental or context system. Otherwise, that is, without the environmental system, the arithmetical system of the acceptance system, here X, has to be accepted as unique, fundamental and pre-given.

2. Somit kann man den diamond systemtheoretisch wie folgt darstellen

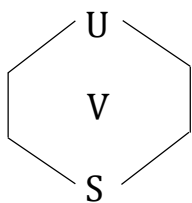

d.h. für die Konkatenation V der Morphismen

$$V = (a \rightarrow b) \circ (b \rightarrow c) = (a \rightarrow c)$$

gilt somit

$$V = S \cap U$$

mit

$$U = S^{-1}.$$

Damit bekommen wir die bereits in Toth (2015) eingeführte ontische Systemrelation

$$S^* = (S, U, E),$$

wobei

$$E = V(S, U),$$

d.h. der kaehrsche diamond ist triadisch und nicht dyadisch, auch wenn Kaehr lediglich „system“ und „environment“ unterscheidet.

Somit kann man einen diamond mengentheoretisch wie folgt darstellen

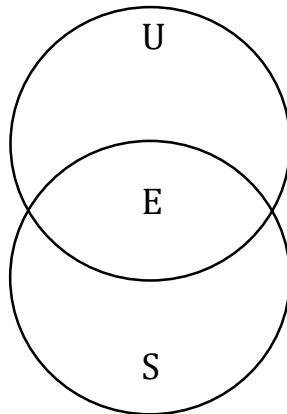

S^* muß daher ordnungstheoretisch durch

$$S^* = (S, E, U)$$

und die peircesche Zeichenrelation vermöge ontisch-semiotischer Isomorphie durch

$$Z = (O, M, I)$$

redefiniert werden. Damit ergeben sich nun die interessanten neuen Teilisomorphien

$$S \cong O$$

$$E = M$$

$$U = I,$$

womit also die neue Systemrelation außerdem der von Bense (1971) eingeführten Kommunikationsrelation $K = (O, M, I)$ isomorph ist. Vor allem aber fungieren Abschlüsse E nun nicht mehr drittheitlich, sondern erstheitlich, und zwar konform dem Mittelbezug als „Medium“ (Peirce), das zwischen Objekt und Interpretant innerhalb von Z vermittelt. Die Umgebung ist somit nicht mehr zweit-, sondern drittheitlich, d.h. als semiotisches Objekt fungiert das System, und als semiotischer Interpretant die Umgebung, die also durch Abschlüsse vermittelt werden.

3. E wird damit zum ontischen Rand, von dem die folgenden Typen unterschieden wurden (vgl. Toth 2019)

3.1. $E(S) \cap E(U) = \emptyset$

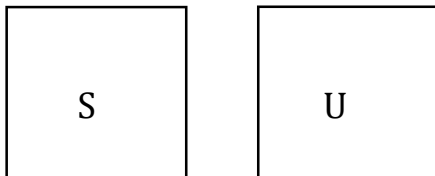

3.2. $E(S) \cap E(U) \neq \emptyset$

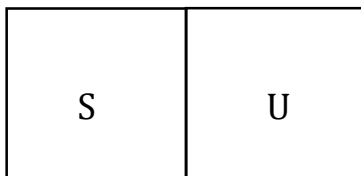

3.3. $E(S) \subset U$ oder $E(U) \subset S$

3.3.1. $E(U) \subset S$

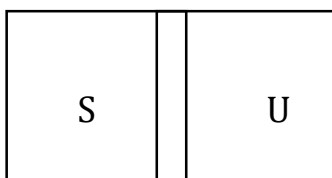

3.3.2. $E(S) \subset U$

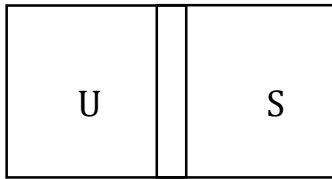

Literatur

Bense, Max, Zeichen und Design. Baden-Baden 1971

Kaehr, Rudolf, The Book of Diamonds. Glasgow 2007. Digitalisat:
www.vordenker.de/rk/rk_Diamond-Theory_collection-of-papers-and-fragments_2007.pdf

Toth, Alfred, Zu einer triadischen System-Definition. In: Electronic Journal for Mathematical Semiotics, 2015

Toth, Alfred, Drei Definitionen von Rändern. In: Electronic Journal for Mathematical Semiotics, 2019

Triadische ontische Vermittlungsrelationen

1. Wie wir in Toth (2019) anhand des diamond-Modells (vgl. Kaehr 2007) gezeigt hatten, muß die in Toth (2015) eingeführte Systemrelation

$$S^* = (S, U, E)$$

ordnungstheoretisch durch

$$S^* = (S, E, U)$$

und die peircesche Zeichenrelation vermöge ontisch-semiotischer Isomorphie durch

$$Z = (O, M, I)$$

redefiniert werden. Damit ergeben sich nun die interessanten neuen Teilisomorphien

$$S \cong O$$

$$E = M$$

$$U = I,$$

womit also die neue Systemrelation außerdem der von Bense (1971) eingeführten Kommunikationsrelation $K = (O, M, I)$ isomorph ist. Vor allem aber fungieren Abschlüsse E nun nicht mehr drittheitlich, sondern erstheitlich, und zwar konform dem Mittelbezug als „Medium“ (Peirce), das zwischen Objekt und Interpretant innerhalb von Z vermittelt. Die Umgebung ist somit nicht mehr zweit-, sondern drittheitlich, d.h. als semiotisches Objekt fungiert das System, und als semiotischer Interpretant die Umgebung, die also durch Abschlüsse vermittelt werden.

2. In einem weiteren Schritt fragen wir uns, welche weiteren der 10 ontisch-invarianten Relationen isomorph zu $Z = (O, M, I)$ geordnet sind.

$$2.1. R^* = (Ad, Adj, Ex)$$

Offenbar gilt

$$Adj = V(Ad, Ex),$$

vgl. etwa das folgende ontische Modell



Rest. Le Paname, Paris.

2.2. $C = (X\lambda, Yz, Z\rho)$

Offenbar gilt auch hier

$Yz = V(X\lambda, Z\rho)$,

vgl. etwa das folgende ontische Modell



Rue Saint-Georges, Paris.

2.3. Interessanter ist

$O = (\text{Sub}, \text{Koo}, \text{Sup})$

mit

$\text{Koo} = V(\text{Sub}, \text{Sup})$,

denn O ist ontisch orthogonal zu R^* , aber auch zu C , vgl. das folgende ontotopologische Schema

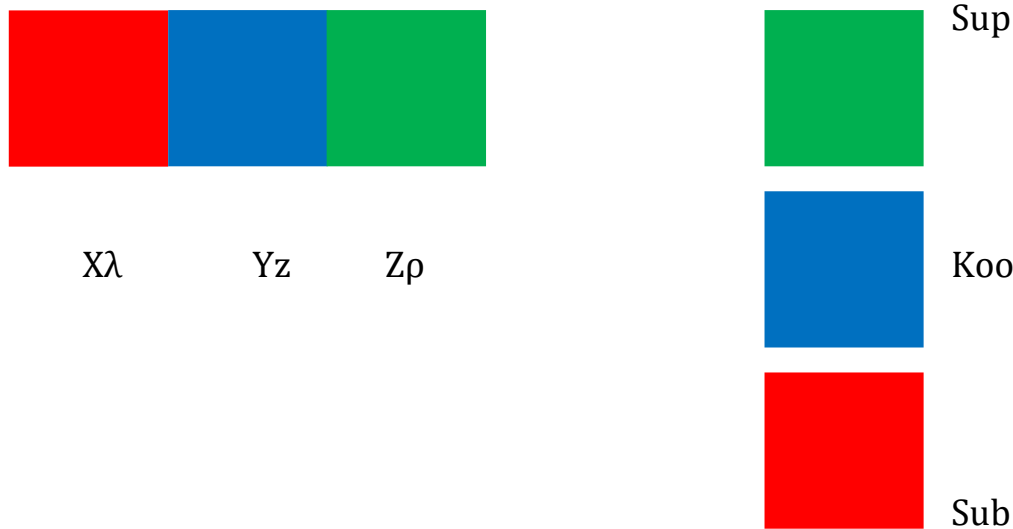

Denkt man sich nun O statt von unten nach oben von vorn nach hinten angeordnet, ist es bis auf die Raumdimension isomorph mit R^* . Denkt man sich schließlich R^* statt von vorn nach hinten von links nach rechts angeordnet, dann sind auch R^* und C und damit R^* , C und O paarweise bis auf ihre Dimension einander isomorph. Ferner kann man offenbar mit Hilfe dieser drei invarianten ontischen Relationen ein 3-dimensionales Objekt ontotopologisch vollständig beschreiben.

Literatur

Bense, Max, Zeichen und Design. Baden-Baden 1971

Kaehr, Rudolf, The Book of Diamonds. Glasgow 2007. Digitalisat:

www.vordenker.de/rk/rk_Diamond-Theory_collection-of-papers-and-fragments_2007.pdf

Toth, Alfred, Zu einer triadischen System-Definition. In: Electronic Journal for Mathematical Semiotics, 2015

Toth, Alfred, System, Umgebung und ihre Vermittlung im kaehrschen diamond-Modell. In: Electronic Journal for Mathematical Semiotics, 2019

Zwei Probleme in der kaehrschen Diamond Theory

1. Bekanntlich erweitert das von Rudolf Kaehr (2007) eingeführte diamond-Modell die Komposition von Morphismen um eine rückwärts gerichtete Abbildung, die Kaehr „Heteromorphismus“ nennt. Während die Komposition zweier Morphismen als System eingeführt wird, stellen sowohl die konkatenierte Abbildung (Akzeption) als auch die Abbildung der Domäne der 2. Abbildung auf die Codomäne der 1. Abbildung innerhalb der Kompositon (Rejektion) Umgebungen dar: Die Konkatenation wird in interne und der Heteromorphismus als externe Umgebung definiert. Jedes System – egal, ob es logisch, mathematisch oder semiotisch mit Hilfe eines diamonds dargestellt wird –, besitzt somit nicht nur eine, sondern zwei Umgebungen (vgl. Kaehr 2007, S. 68).

Diamond System Scheme

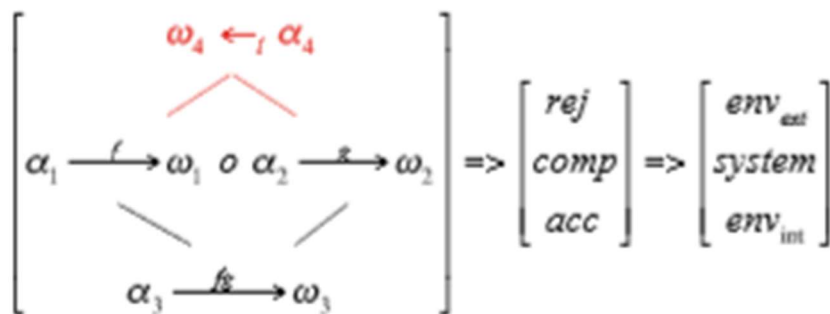

Während also der mittlere und der untere Teil des diamonds mit Hilfe der quantitativen Kategorientheorie definierbar sind, ist es der obere Teil nicht. Diese auch „jumpoid“ oder „saltatory“ genannte Abbildung ist qualitativ, weil sie sich von der Komposition durch die Kontexturen unterscheidet. Ein diamond erfordert somit mindestens 4 Kontexturen

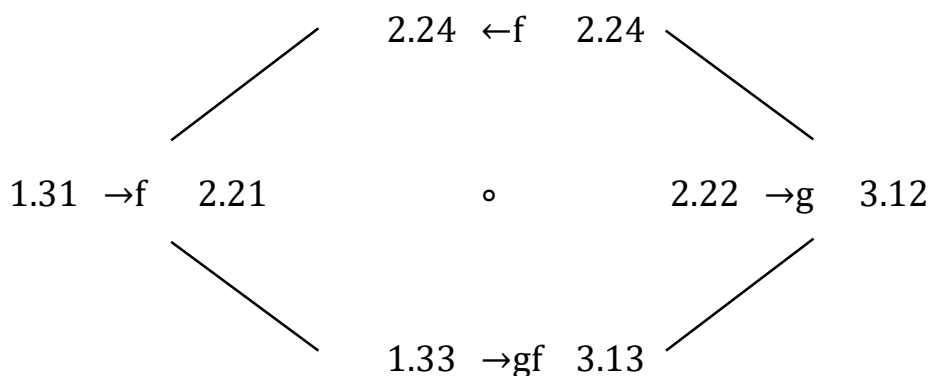

Bei 1-kontexturalen Systemen wie etwa der Peirce-Bense-Semiotik, wird somit der diamond trivial, vgl. etwa

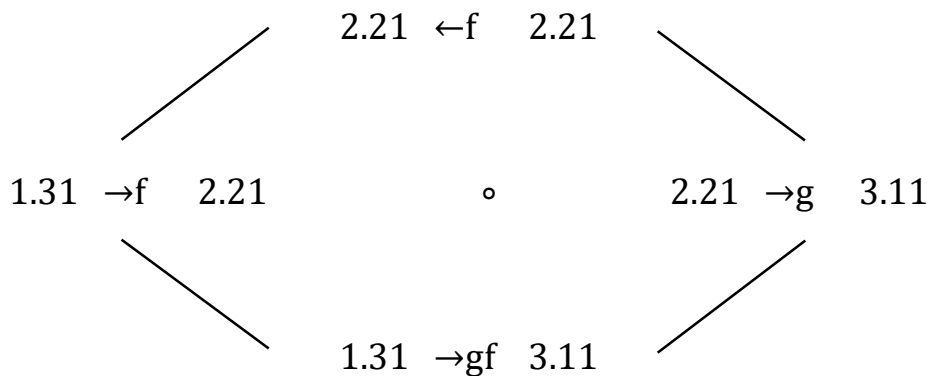

denn hier gilt

$$(2.21 \rightarrow 2.21)^{-1} = (2.21 \leftarrow 2.21).$$

2. Wie man sieht, funktioniert innerhalb der Semiotik das diamond-Modell ohne Probleme, solange man die quantitativen Subrelationen der Zeichenzahlen kontexturiert. Was aber geschieht, wenn man direkt von semiotischen Morphogrammen ausgeht (vgl. Toth 2019)?

2.1. Problem 1

Bestimmte Morphogramme tauchen nur in einer der drei qualitativen Zahlen pro Kontextur auf. Ein Beispiel ist (011), das nur Tritozahl sein kann. Wenn nun diese Zahl Codomäne einer ersten Abbildung und Domäne einer zweiten Abbildung einer morphismischen Komposition ist,

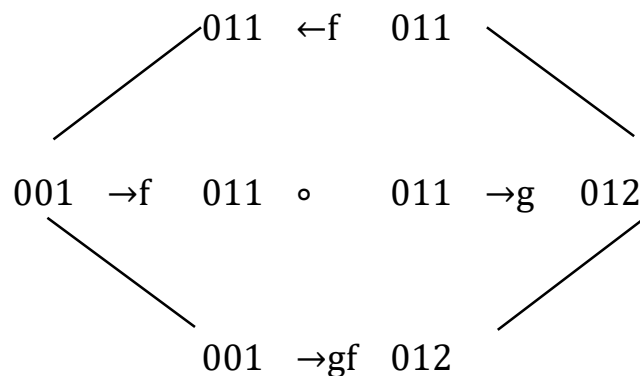

dann wird der diamond, wie schon oben im monokontexturalen semiotischen Beispiel, trivial, da erstens natürlich alle Zahlen des diamonds aus $K = 3$ sind, aber (011) im Gegensatz zu (001) und (012) nicht Proto- oder Tritozahl sein kann.

Hier gilt also: 1. Jedes Morphogramm liegt in einer und nur einer Kontextur.
2. Der diamond enthält Morphogramme aus 3 Kontexturen

f: $001 \rightarrow 01$

g: $01 \rightarrow 0110$,

d.h. $K(01) = 2$, $K(001) = 3$ und $K(0110) = 4$.

Literatur

Kaehr, Rudolf, The Book of Diamonds. Glasgow 2007. Digitalisat:
http://www.vordenker.de/rk/rk_Diamond-Theory_collection-of-papers-and-fragments_2007.pdf

Kaehr, Rudolf, Diamond-Semiotic Short Studies. Glasgow 2009. Digitalisat:
www.vordenker.de/rk/rk_Diamond-Semiotic_Short-Studies_2009.pdf

Toth, Alfred, Eine minimale vollständige polykontexturale Semiotik für $K = 4$. In: Electronic Journal for Mathematical Semiotics, 2019

In wie vielen Kontexturen können Subzeichen einer triadischen Semiotik liegen?

1. In der der monokontexturalen triadisch-trichotomischen Semiotik (vgl. Bense 1975, S. 35 ff.) entsprechenden qualitativen Matrix können die Subzeichen maximal in 2 Kontexturen liegen (vgl. Kaehr 2009, S. 71). Ferner ist die Abbildung der Kontexturen auf die Subzeichen bijektiv, d.h. nur zueinander duale Subzeichen befinden sich in der gleichen Kontextur.

$$\text{polycontextural semiotic 3 - matrix}$$

$$\text{Sem}^{(3,2)} = \begin{pmatrix} \text{MM} & 1_{1,3} & 2_{1,2} & 3_{2,3} \\ 1_{1,3} & \mathbf{1.1}_{1,3} & \mathbf{1.2}_1 & \mathbf{1.3}_3 \\ 2_{1,2} & \mathbf{2.1}_1 & \mathbf{2.2}_{1,2} & \mathbf{2.3}_2 \\ 3_{2,3} & \mathbf{3.1}_3 & \mathbf{3.2}_2 & \mathbf{3.3}_{2,3} \end{pmatrix}$$

Die Abbildung von Kontexturen auf Subzeichen beruht auf dem folgenden Mediationsschema der semiotischen Matrix aus 3 Teilmatrizen (vgl. Kaehr 2009, S. 192).

$$\text{mediation}(\text{Semiotics}^{(3,2)}) = \begin{bmatrix} (1.1)_1 \rightarrow (2.2)_1 & & \square \\ \square & \updownarrow & \\ \square & (2.2)_2 \rightarrow (3.3)_2 & \\ | & & | \\ (1.1)_3 \rightarrow & \rightarrow & (3.3)_3 \end{bmatrix}$$

2. Ganz anders sieht es aber aus, wenn man, statt die Subzeichen zu kontexturieren, den umgekehrten Weg geht und direkt Morphogramme bestimmter Länge, d.h. Kontextur, mit semiotischen Werten (z.B. Subzeichen) belegt (vgl. Toth 2019)

Protozahlen	Deuterozahlen	Tritozahlen	Kontextur
1.1	1.1	1.1	K = 1

1.1	1.1	1.1	K = 2
1.2	1.2	1.2	

1.1	1.1	1.1	K = 3
1.2	1.2	1.2	
—	—	1.4	
—	—	1.5	
1.3	1.3	1.3	

1.1	1.1	1.1	K = 4,
1.2	1.2	1.2	
—	—	1.4	
—	1.5	1.5	
1.3	1.3	1.3	
—	—	2.1	
—	—	2.2	
—	—	2.4	
—	—	2.5	
—	—	2.3	
—	—	3.1	
—	—	3.2	
—	—	3.4	
—	—	3.5	
3.3	3.3	3.3	

In diesem Falle müssen die beiden Formen von qualitativer Teilmengenschaft erfüllt sein, d.h. es muß gelten

interkontexturell

$(K = 1) \subset (K = 2) \subset (K = 3) \subset (K = 4)$

und intrakontexturell

$(\text{Proto-K} = 4) \subset (\text{Deutero-K} = 4) \subset (\text{Trito-K} = 5).$

Im folgenden ordnen wir nun die Subzeichen den möglichen Kontexturen zu, in denen sie sich befinden (wobei wir die Subzeichen der Form $S = (x.y)$ mit $y \in (3, 4)$ weglassen, da wir in Toth (2019) ja von einer triadisch-tetratomischen Matrix ausgegangen waren).

Subzeichen	Kontexturen
1.1	1, 2, 3, 4
1.2	2, 3, 4
1.3	3, 4
2.1	4
2.2	4
2.3	4
3.1	4
3.2	4
3.3	4

Wie man sieht, kommt also nur der Mittelbezug in mehr als 1 Kontextur vor. Eine Matrix kontexturierter Subzeichen würde also wie folgt aussehen

	.1	.2	.3
1.	1.11.2.3.4	1.22.3.4	1.33.4
2.	2.14	2.24	2.34
3.	3.14	3.24	3.34

Literatur

Bense, Max, Semiotische Prozesse und Systeme. Baden-Baden 1975

Kaehr, Rudolf, Diamond-Semiotic Short Studies. Glasgow 2009. Digitalisat: www.vordenker.de/rk/rk_Diamond-Semiotic_Short-Studies_2009.pdf

Toth, Alfred, Eine minimale vollständige polykontexturale Semiotik für $K = 4$. In: Electronic Journal for Mathematical Semiotics, 2019

Graphen kontexturierter Zeichenklassen

1. Die Abbildung von Kontexturen auf Subzeichen beruht auf dem folgenden Mediationsschema der semiotischen Matrix aus 3 Teilmatrizen (vgl. Kaehr 2009, S. 192).

$$\text{mediation}(\text{Semiotics}^{(3,2)}) = \begin{bmatrix} (1.1)_1 \rightarrow (2.2)_1 & \square & \\ \square & \updownarrow & \\ \square & (2.2)_2 \rightarrow (3.3)_2 & \\ | & & | \\ (1.1)_3 \rightarrow & \rightarrow & (3.3)_3 \end{bmatrix}$$

In der der monokontexturalen triadisch-trichotomischen Semiotik (vgl. Bense 1975, S. 35 ff.) entsprechenden qualitativen Matrix können die Subzeichen maximal in 2 Kontexturen liegen. Ferner ist die Abbildung der Kontexturen auf die Subzeichen bijektiv, d.h. nur zueinander duale Subzeichen befinden sich in der gleichen Kontextur (Kaehr 2009, S. 71).

polycontextural semiotic 3 - matrix			
$\text{Sem}^{(3,2)} =$	$\begin{pmatrix} \text{MM} & 1_{1,3} & 2_{1,2} & 3_{2,3} \\ 1_{1,3} & \mathbf{1.1}_{1,3} & \mathbf{1.2}_1 & \mathbf{1.3}_3 \\ 2_{1,2} & \mathbf{2.1}_1 & \mathbf{2.2}_{1,2} & \mathbf{2.3}_2 \\ 3_{2,3} & \mathbf{3.1}_3 & \mathbf{3.2}_2 & \mathbf{3.3}_{2,3} \end{pmatrix}$		

2. Wir stellen im folgenden die Subzeichen der Form $S = (x.y)$ mit $x, y \in (1, 2, 3)$ in Funktion ihrer Kontexturen $K = (1, 2, 3)$, d.h. $S = f(K)$, für jede der 10 Zeichenklassen dar.

2.1. $(3.1, 2.1, 1.1) = f(K)$

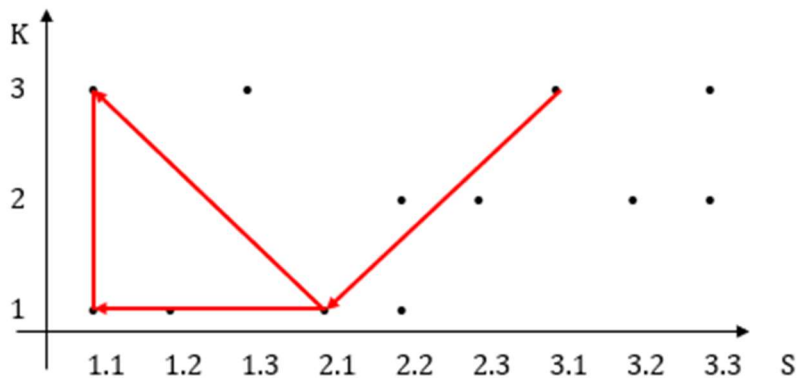

2.2. $(3.1, 2.1, 1.2) = f(K)$

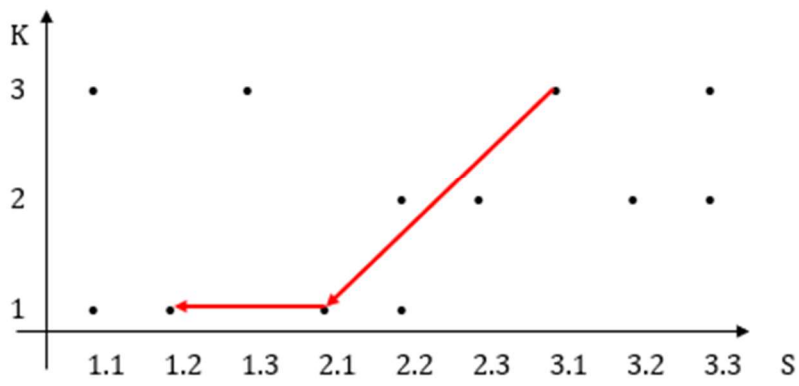

2.3. $(3.1, 2.1, 1.3) = f(K)$

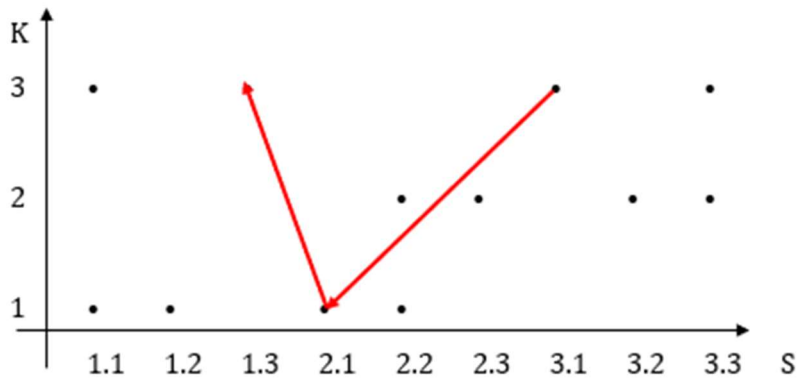

2.4. $(3.1, 2.2, 1.2) = f(K)$

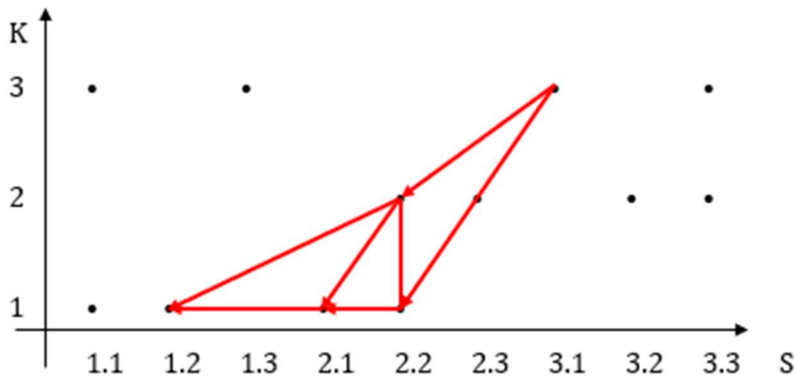

2.5. $(3.1, 2.2, 1.3) = f(K)$

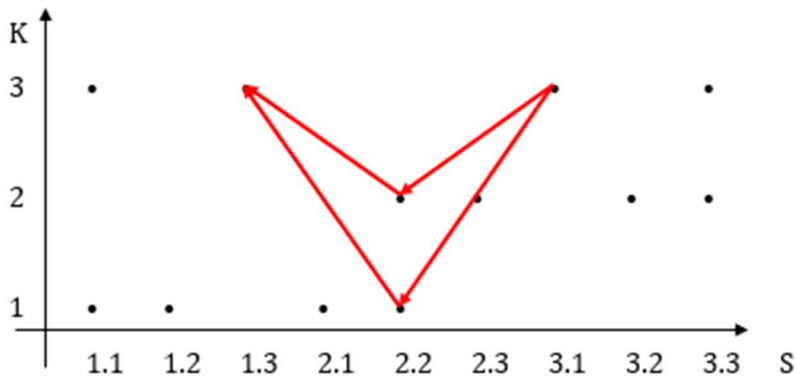

2.6. $(3.1, 2.3, 1.3) = f(K)$

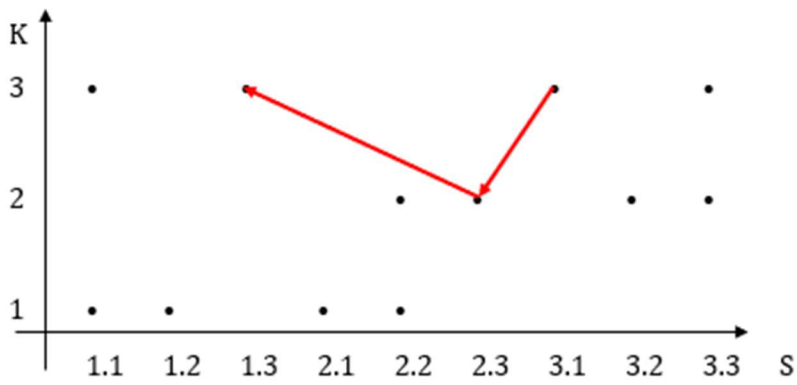

2.7. $(3.2, 2.2, 1.2) = f(K)$

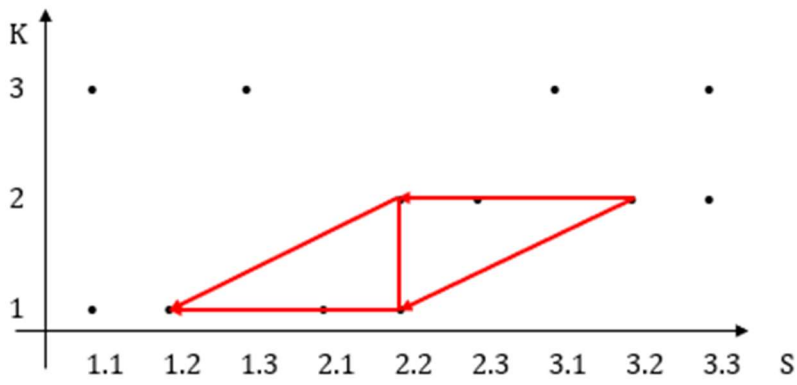

2.8. $(3.2, 2.2, 1.3) = f(K)$

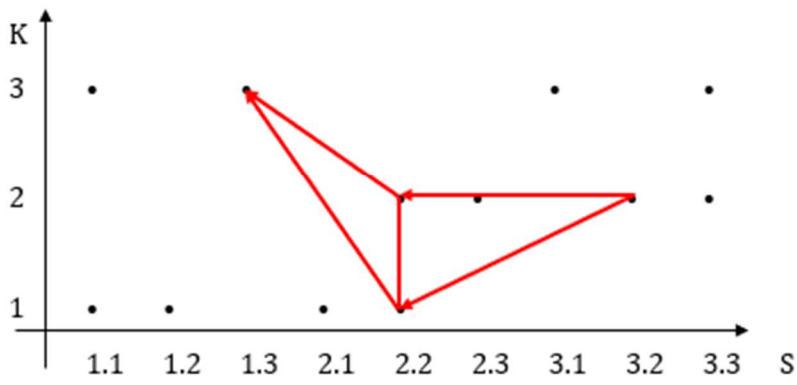

2.9. $(3.2, 2.3, 1.3) = f(K)$

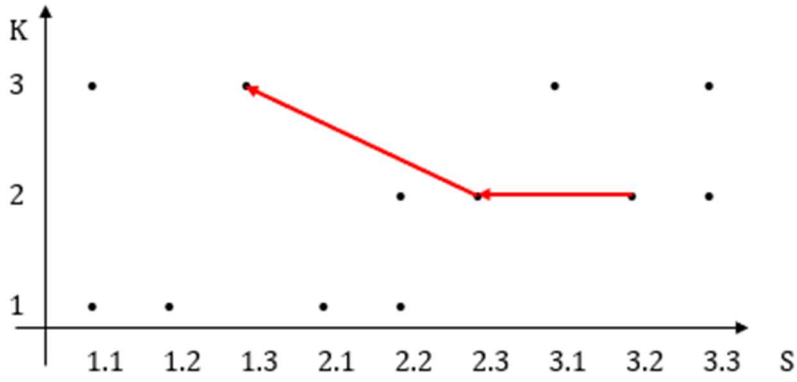

2.10. $(3.3, 2.3, 1.3) = f(K)$

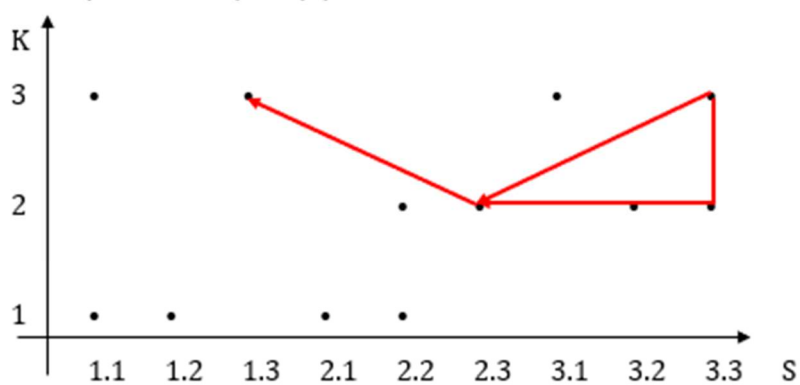

Vgl. dazu noch den Graphen der Kategorienklasse (der Hauptdiagonalen der semiotischen Matrix).

2.11. $(3.3, 2.2, 1.1) = f(K)$

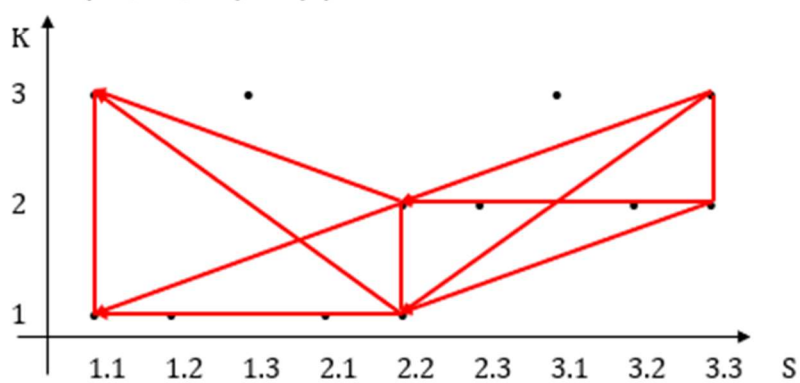

Literatur

Bense, Max, Semiotische Prozesse und Systeme. Baden-Baden 1975

Kaehr, Rudolf, Diamond-Semiotic Short Studies. Glasgow 2009. Digitalisat:
www.vordenker.de/rk/rk-Diamond-Semiotic-Short-Studies-2009.pdf

Kontexturierte Zeichenzahlen mit Einbettungsoperatoren

1. Sei

$$S = (x.y)$$

mit $x, y \in (1, 2, 3)$.

Wir verwenden den in Toth (2015) eingeführten Einbettungsoperator

$$E: x \rightarrow (x).$$

Damit bekommen wir für jedes S genau 6 Möglichkeiten

$$(x.y), ((x.y))$$

$$((x).y), (y.(x))$$

$$(x.(y)), ((y).x),$$

davon also 2 zueinander E-duale Paare.

2. Gehen wir nun aus von der Kontexturierung der von Bense (1981, S. 17 ff.) eingeführten Zeichenzahlen durch Kaehr (2009)

polycontextural semiotic 3 – matrix				
$Sem^{(3,2)} =$	MM	$1_{1,3}$	$2_{1,2}$	$3_{2,3}$
	$1_{1,3}$	1.1 _{1,3}	1.2 ₁	1.3 ₃
	$2_{1,2}$	2.1 ₁	2.2 _{1,2}	2.3 ₂
	$3_{2,3}$	3.1 ₃	3.2 ₂	3.3 _{2,3}

Wir haben also folgende Abbildung quantitativer auf qualitative Zeichenzahlen

$$P(1, 2, 3) \rightarrow P^* = (11.3, 21.2, 32.3).$$

Damit fallen die Zeichenzahlen kontexturell mit den entsprechenden identitiven Morphismen zusammen

$$11.3 \leftrightarrow (1.1)1.3$$

21.2 ↔ (2.2)1.2

32.3 ↔ (3.3)2.3.

Der Grund hierfür ist der, daß die Abbildung von Kontexturen auf Subzeichen auf dem folgenden Mediationsschema der semiotischen Matrix aus 3 Teilmatrizen (vgl. Kaehr 2009, S. 192) beruht.

$$\text{mediation}(\text{Semiotics}^{(3,2)}) = \left[\begin{array}{ccc} (1.1)_1 \rightarrow (2.2)_1 & & \square \\ \square & \updownarrow & \\ \square & (2.2)_2 \rightarrow (3.3)_2 & \\ | & & | \\ (1.1)_3 \rightarrow & \rightarrow & (3.3)_3 \end{array} \right]$$

3. Wir erhalten damit folgende 6 kontexturierte Zeichenzahlen

(x.y)□□, ((x.y))□□

((x).y)□□, (y.(x))□□

(x.(y))□□, ((y).x)□□

mit □□ ∈ (1, 2, 3),

also etwa für ×(1.2)1 = (2.1)1

(1.2)1, ((1.2))1

((1).2)1, (2.(1))1

(1.(2))1, ((2).1).

Literatur

Bense, Max, Axiomatik und Semiotik. Baden-Baden 1981

Kaehr, Rudolf, Diamond-Semiotic Short Studies. Glasgow 2009. Digitalisat:
www.vordenker.de/rk/rk_Diamond-Semiotic_Short-Studies_2009.pdf

Toth, Alfred, Die Logik des Jägers Gracchus. In: Electronic Journal for Mathematical Semiotics, 2015

Zahlentheoretische Vermittlung in der quantitativen und in der qualitativen Semiotik

1. Nach Peirce besteht die Zeichenrelation bekanntlich aus drei universalen Kategorien, die er relationentheoretisch als Mittelbezug (M), Objektbezug (O) und Interpretantenbezug (I) des Zeichens eingeführt hatte. Obwohl M also zwischen O und I vermittelt, werden folgende Zuordnungen vorgenommen (vgl. Bense 1981, S. 17ff.)

$$M = 1$$

$$O = 2$$

$$I = 3,$$

d.h. M wird als 1-stellige, O als 2-stellige und I als 3-stellige Relation bestimmt.

2. Nun kann allerdings eine 1-stellige Relation nicht vermitteln. Man würde wegen

$$1 = V(2, 3)$$

und entsprechend für die Subzeichen $S = (x,y)$ mit $(x,y) \subset Z \times Z$

$$(1.1) = V(1.2, 1.3)$$

$$(2.1) = V(2.2, 2.3)$$

$$(3.1) = V(3.2, 3.3),$$

also die folgende permutierte Ordnung der Zeichenrelation

$$Z = (2, 1, 3),$$

erwarten, der jedoch nach Bense (1971) nur für die semiotische Kommunikationsrelation zugelassen ist.

3. Einen ganz anderen Ansatz hatte Kaehr innerhalb der Semiotik verfolgt. Er konstruierte eine qualitative Semiotik aus der von Bense (1975, S. 35 ff.) eingeführten Matrix, indem er die Subzeichen kontexturierte (vgl. Kaehr 2009, S. 72)

polycontextural semiotic 3 – matrix				
Sem ^(3,2) =	MM	1 _{1,3}	2 _{1,2}	3 _{2,3}
	1 _{1,3}	1.1 _{1,3}	1.2 ₁	1.3 ₃
	2 _{1,2}	2.1 ₁	2.2 _{1,2}	2.3 ₂
	3 _{2,3}	3.1 ₃	3.2 ₂	3.3 _{2,3}

Wie man leicht sieht, erhalten in dieser polykontexturalen Matrix also die genuinen Subzeichen, d.h. die identischen Abbildungen der Zeichenzahlen, keine eigene Kontextur, sondern sie liegen alle in zwei Kontexturen, nämlich in denen der von ihnen vermittelten Subzeichen

$$(1.1)1.3 = V(1.21, 1.33)$$

$$(2.2)1.2 = V(2.11, 2.22)$$

$$(3.3)2.3 = V(3.22, 3.13,).$$

Daraus folgen nun aber folgende permutierte Ordnung von Z

$$(1.1)1.3 = V(1.21, 1.11.3, 1.33)$$

$$(2.2)1.2 = V(2.11, 2.21.2, 2.32)$$

$$(3.3)2.3 = V(3.22, 3.32.3, 3.13,).$$

d.h. wir haben

$$Z1 = (2, 1, 3)$$

$$Z2 = (1, 2, 3)$$

$$Z3 = (2, 3, 1).$$

Die quantitative Permutationsordnung (2, 1, 3) findet sich also beim qualitativen Zeichen nur im erstheitlichen Bezug. Ferner weist der qualitative zweitheitliche Bezug die Ordnung der von Peirce eingeführten Zeichenrelation auf. Bemerkenswerterweise können hier jedoch alle 3 Zeichenzahlen vermitteln: in Z1 bis Z3 haben wir ja von oben nach $V = 1, V = 2, V = 3$.

Literatur

Bense, Max, Zeichen und Design. Baden-Baden 1971

Bense, Max, Semiotische Prozesse und Systeme. Baden-Baden 1975

Bense, Max, Axiomatik und Semiotik. Baden-Baden 1981

Kaehr, Rudolf, Diamond-Semiotic Short Studies. Glasgow 2009. Digitalisat:
www.vordenker.de/rk/rk_Diamond-Semiotic_Short-Studies_2009.pdf